



SFC-500 SERIES FIRE ALARM PANEL



INSTALLATION INSTRUCTIONS

Canada
25 Interchange Way
Vaughan, ON L4K 5W3

U.S.A.
4575 Witmer Industrial Estates
Niagara Falls, New York 14305

Phone: 1-866-SUMMIT-0 (1-866-786-6480)

Fax: 1-888-660-4113

www.summit-st.net

Table of Contents

List of Figures	ii
FCC Notice	1
Introduction	2
Conventions	3
System Components	4
Panel Models	4
Output Class A converter: four circuits	4
Polarity reversal/city tie	4
Remote Annunciator	5
Smart Relay Module	5
SRAM-216 Remote Annunciator.....	5
Panel Components and System Accessories	6
Analog/Addressable Devices	7
Mechanical Installation	8
Installing Adder Modules	10
Circuits and Devices	14
Field Wiring	16
Main Fire Alarm Board Field Wiring	16
Loop Isolators	16
Loop Operation	17
Indicating (Powered Output) Circuits	18
Indicating Circuit Wiring	18
Dialer Wiring	20
Polarity Reversal and City Tie Module (SPR-200) Wiring	21
Auxiliary Power Supplies	22
Power Supply Connections.....	23
System Checkout	24
Troubleshooting	24
Indicators, Controls and Operations	25
Remote Annunciators Operation	34
Dialer Operation	35
Appendix A: Compatible Receivers	35
Appendix B: Reporting	36
Appendix C: Specifications	38
Appendix D: Power Supply and Battery Calculations	39
Warranty & Warning Information	41

List of Figures

Figure 1: Wallbox Dimensions / Mounting the SFC-500 - Surface.....	8
Figure 2: Mounting the SFC-500 - Flush	9
Figure 3: Flush Trim Detail	9
Figure 4: Installation of Adder Modules	10
Figure 5: Main Fire Alarm Board Cable Connectors and Jumper Locations	11
Figure 6: SOCA-204 Output Class A Converter Adder Modules.....	12
Figure 7: Polarity Reversal and City Tie Module	13
Figure 8: Addressable Loop Wiring - Class B or Style 4	16
Figure 9: Addressable Loop Wiring -Class A or Style 6	17
Figure 10: Indicating Circuit – Class B or Style Y Wiring	19
Figure 11: Indicating Circuit –Class A or Style Z Wiring.....	19
Figure 12: Dialer Wiring	20
Figure 13: Polarity Reversal and City Tie Module Terminal Connection	21
Figure 14: Supervision Of Auxiliary Supplies	22
Figure 15: Main Power Supply Connections	23
Figure 16: LCD Display, LED indicators and control buttons	25
Figure 17: Evacuation Codes	31

FCC Notice

Notice for all SFC-500 Series Built-in UDACTs Sold in the U.S.A.



Note: The Ringer Equivalence Number (REN) assigned to each terminal device provides an indication of the maximum number of terminals allowed to be connected to a telephone interface. The termination on an interface may consist of any combination of devices subject only to the requirement that the sum of the Ringer Equivalence Numbers of all the devices does not exceed 5.

The REN for this product is part of the product identifier that has the format US:1M8AL02BFX350. The 02B represents the REN without a decimal point (e.g., 02B is a REN of 0.2B). For earlier products, the REN is separately shown on the label.

Summit's SFC-500 SERIES BUILT-IN UDACT Digital Communicator described in this manual is listed by Underwriters Laboratories Inc. (ULI) for use in slave application in conjunction with a Listed Fire Alarm Control Panel under Standard 864 (Control Units for Fire Protective Signalling Systems). These Communicators comply with the National Fire Protection Association (NFPA) performance requirements for UDACTs and should be installed in accordance with NFPA 72 Chapter 4 (Supervising Station Fire Alarm System). These Communicators should be installed in accordance with this manual; the National Electrical Code (NFPA 70); and/or the local Authority Having Jurisdiction (AHJ).

FCC Notice

This equipment complies with Part 68 of the FCC rules and the requirements adopted by the ACTA. On the telco transformer of this equipment is a label that contains, among other information, a product identifier in the format US:1M8AL02BFX350. If requested, this number must be provided to the telephone company. This equipment is capable of seizing the line. This capability is provided in the hardware.

Type of Service: The **Communicator** is designed to be used on standard device telephone lines. It connects to the telephone line by means of a standard jack called the USOC RJ-11C (or USOC FJ45S). Connection to telephone company provided coin service (central office implemented systems) is prohibited. Connection to party lines service is subject to state tariffs.

Telephone Company Procedures: The goal of the telephone company is to provide you with the best service it can. In order to do this, it may occasionally be necessary for them to make changes in their equipment, operations or procedures. If these changes might affect your service or the operation of your equipment, the telephone company will give you notice, in writing, to allow you to make any changes necessary to maintain uninterrupted service.

In certain circumstances, it may be necessary for the telephone company to request information from you concerning the equipment which you have connected to your telephone line. Upon request of the telephone company, provide the FCC registration number and the ringer equivalence number (REN); both of these items are listed on the equipment label. The sum of all of the REN's on your telephone lines should be less than five in order to assure proper service from the telephone company. In some cases, a sum of five may not be usable on a given line.

If Problems Arise: If any of your telephone equipment is not operating properly, you should immediately remove it from your telephone line, as it may cause harm to the telephone network. If the telephone company notes a problem, they may temporarily discontinue service. When practical, they will notify you in advance of this disconnection. If advance notice is not feasible, you will be notified as soon as possible. When you are notified, you will be given the opportunity to correct the problem and informed of your right to file a complaint with the FCC. Contact your telephone company if you have any questions about your phone line. In the event repairs are ever needed on the Communicator, they should be performed by Summit Systems Technologies or an authorized representative of Summit Systems Technologies. For information contact Summit Systems Technologies at the address and phone numbers shown on the back page of this document.

Introduction

Summit's **SFC-500** Series Analog/Addressable Fire Alarm Control Panel provides a loop for 60 or 126 addressable input and output devices, four supervised Class B or A (Style Y or Z) indicating circuits, a full range of auxiliary power supplies, and extensive common control features via its integrated LCD display and push button console. Many of its features are fully configurable utilizing the built-in configuration capability via the front panel display and switches. The panel is available with an integrated dialer/modem. Optional modules include Polarity Reversal and City Tie, and Class A Converter for indicating circuits. Semi-flush or surface mountable enclosures can be used for retrofits and on new installations. This manual covers the following panels:

SFC-500-60-DR One Loop (60 devices) Panel, c/w dialer, red door
 SFC-500-126-DR One Loop (126 devices) Panel, c/w dialer, red door



Note: Installation of the SFC-500 Series Fire Alarm Control panel should be in accordance with National Electrical Code NFPA 70 and NFPA 72. Final acceptance subject to the Local Authority Having Jurisdiction (AHJ).

Features

- The SFC-500 panels support a loop of 60 or 126 addressable devices, including thermal, ion, photo detectors, and contact input and output devices. Drift compensation and Auto Test features are provided for analog devices.
- Four Power Limited Class B (Style Y) indicating circuits. Each indicating circuit may be configured as Class A (Style Z) using an output Class A converter adder module. Each indicating circuit may be configured as silenceable signal, non-silenceable signal, silenceable strobes, non-silenceable strobes, or relay output. The audible signal may be Steady, Temporal Code, California Code, or March Time. The system provides the necessary protocols to sync strobes from major manufacturers.
- Configurable Signal Silence Inhibit, Auto Signal Silence, and One-Man Walk Test.
- Subsequent Alarm, Supervisory, and Trouble operation.
- provides a regulated, supervised 21.1VDC auxiliary power supply @ 500mA max.; unfiltered, unsupervised 24V FWR power supply @ 1.7 A max and a resettable auxiliary power supply @ 300mA max.
- Relay Contacts for Common Alarm, Common Supervisory and Common Trouble all non-disconnectable and Auxiliary Alarm Relay (disconnectable).
- Output for remote trouble indicator and Buzzer.
- RS-485 Interface for SRAM-200LCD Annunciators, SRA-300 Series Remote Annunciators, SRAM-216 and SRAM-208 Remote Annunciators and SSR-212 Smart Relay Modules (max total of 7 remote annunciators).
- Optional Module for City Tie and Polarity Reversal Signaling.
- Extensive transient protection
- Built-in UDACT (Digital Alarm Communicator Transmitter).
- Extensive and easy configuration of the panel via the integrated LCD display and keypad or laptop computer.
- Remote dial up (with built-in UDACT) for event log checking and/or configuration changing

Conventions

Circuits

Refers to a physical electrical interface for the analog loop, indicating signals or relays, and common alarm, supervisory, and trouble relay outputs.

Zone/Group

Is a logical concept for a Fire Alarm Protected Area, and will consist of at least one Circuit. Groups are used to facilitate bypassing of inputs and outputs.

Display Points

The SFC-500 provides an LCD display to annunciate the status of the system and connected devices.

Wiring Styles

The analog loop can be connected in Class B (Style Y) or Class A (Style D) configurations. Changing the indicating circuits to Class A requires an SOCA-204 adder board which will convert four indicating zones from Class B (Style Y) circuits to Class A (Style Z). This is done without reducing the number of circuits.



Note: The Model SFC-500-60DR panels **DO NOT** recognize any devices with addresses higher than 60.

System Components

Panel Models

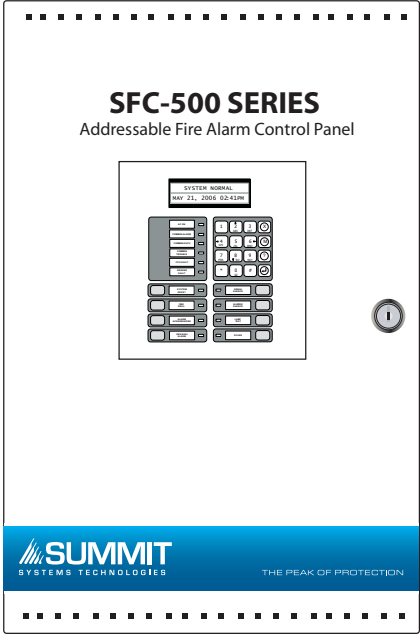
	Model	Description
	<p>SFC-500-60-DR, SFC-500-126-DR</p>	<p>Multi-zone fire alarm control panel with 2 x 20 LCD display, one (Style Y or Style D) analog loop (60 or 126 devices), four Power Limited Class B (Style Y) indicating circuits (max 1.7 Amps each - 5 Amps total), and dedicated common alarm, supervisory, trouble, and auxiliary alarm relays. Both these models have a two line UDACT Digital Communicator and modem included. An optional SOCA-204 Class A converter module may be used to convert the indicating circuits to Class A (Style Z). Additional outputs include connections for a SRTI-200 remote trouble indicator, SPR-200 Reverse Polarity Module, an RS-485 bus for connection of up to seven SRAM-200LCD, SSR-212, SRA-300 Series and SRAM-216/208 annunciators. Auxiliary power is available in the form of 24V FWR unfiltered and unsupervised, 24VDC filtered and regulated, and resettable auxiliary power supply. The panels are available with a red door.</p>

Output Class A converter: four circuits

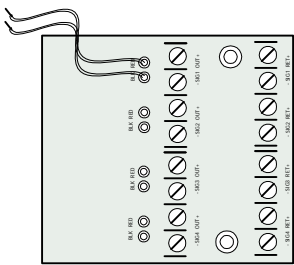
	Model	Description
	<p>SOCA-204</p>	<p>Output Class A converter module (four circuits)</p>

Polarity reversal/city tie

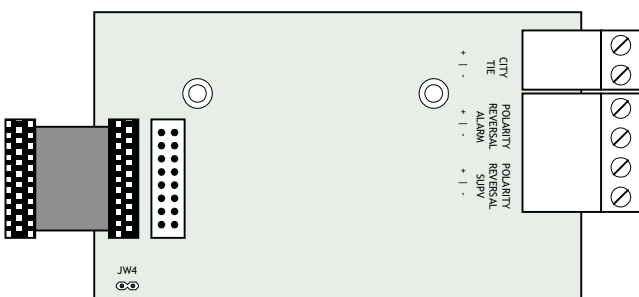
	Model	Description
	<p>SPR-200</p>	<p>Polarity Reversal and/or City Tie Module</p>

Remote Annunciator

	<table border="1"> <thead> <tr> <th>Model</th> <th>Description</th> </tr> </thead> <tbody> <tr> <td>SRAM-200LCDR</td> <td>Remote Annunciator Module, LCD display, red painted box</td> </tr> </tbody> </table>	Model	Description	SRAM-200LCDR	Remote Annunciator Module, LCD display, red painted box	
Model	Description					
SRAM-200LCDR	Remote Annunciator Module, LCD display, red painted box					

Smart Relay Module

	<table border="1"> <thead> <tr> <th>Model</th> <th>Description</th> </tr> </thead> <tbody> <tr> <td>SSR-212R</td> <td>Smart Relay Module (12 relays) with red enclosure</td> </tr> </tbody> </table>	Model	Description	SSR-212R	Smart Relay Module (12 relays) with red enclosure	
Model	Description					
SSR-212R	Smart Relay Module (12 relays) with red enclosure					

SRAM-216 Remote Annunciator

	<table border="1"> <thead> <tr> <th>Model</th> <th>Description</th> </tr> </thead> <tbody> <tr> <td>SRAM-216</td> <td>16 Zone remote annunciator</td> </tr> </tbody> </table>	Model	Description	SRAM-216	16 Zone remote annunciator	
Model	Description					
SRAM-216	16 Zone remote annunciator					

Panel Components and System Accessories

MODEL NO.	DESCRIPTIONS
SRAM-208 / R	8 LED Remote Annunciator
SRAM-316	16 LED Remote Annunciator chassis
SRAM-332 / TZ	Remote Annunciator with 32 bi-colored (red and yellow) LEDs. TZ version has 32 yellow LEDs for trouble indication.
SGD-32	Graphic Annunciator
SGD-048	Graphic Annunciator Adder Driver Board
SRTI-200	Remote Trouble Indicator, Buzzer and LED
SFC-200TRB	Trim Ring For Enclosure (Black)
SBB-301 / R	Enclosure for one annunciator, white. R version is red.
MP-300	End-of-line resistor plate, 3.9K ohm
BC-160	External Battery Cabinet

Analog/Addressable Devices

DESCRIPTION	Summit Model
Ionization Smoke Detector (UL Listed)	SII-200
Photoelectric Smoke Detector	SIP-200
* Multi-sensor (photoelectric with supplemental rate-of-rise heat sensor)	SIM-200
Heat Detector	SIH-200
BASES	
4 inch Standard Base	SIB-4
6 inch E-Z Fit Base	SIB-6
6 inch Base with Relay	SIB-6R
6 inch Base with Sounder	SIB-6S
6 inch Base with Temporal Tone Sounder	SIB-6TH
ANCILLARY MODULES	
Priority Monitor Module	SIM-100P
Mini Priority Monitor Module	SIM-101P
Single Relay Output Module (1 Form C Contacts, 2 Gang Mount)	55000-820
Supervised Control Module	SIM-100S
Isolator c/w Mounting Base	SIM-100X (Kit) 100XH (Isolator) 100XB (Base)
ADDRESSABLE DUCT DETECTORS	
Ionization Duct Smoke Detector (UL Listed)	SIDH-200I
Photoelectric Duct Smoke Detector (UL Listed)	SIDH-200P
Ionization Duct Smoke Detector with relay (UL Listed)	SIDH-200IR
Photoelectric Duct Smoke Detector with relay (UL Listed)	SIDH-200PR
ADDRESSABLE PULL STATIONS	
Addressable Single Stage Single Action Pull Station	SPS-201ID
Addressable Single Stage Dual Action Pull Station	SPS-202ID

* Unit employs an integral heat sensor; however it must not be used as a regular heat detector. Refer to the product data sheet for detailed functionality, operation and application.
Manual configuration for the SIM-200 is NOT PERMITTED. This device must be configured via the AUTO CONFIG.

Mechanical Installation

Installing the Enclosure

Install the SFC-500 Series Fire Alarm Panel enclosure as shown below. Mount the enclosure using the four mounting holes and the screws provided.

Figure 1: Wallbox Dimensions / Mounting the SFC-500 - Surface

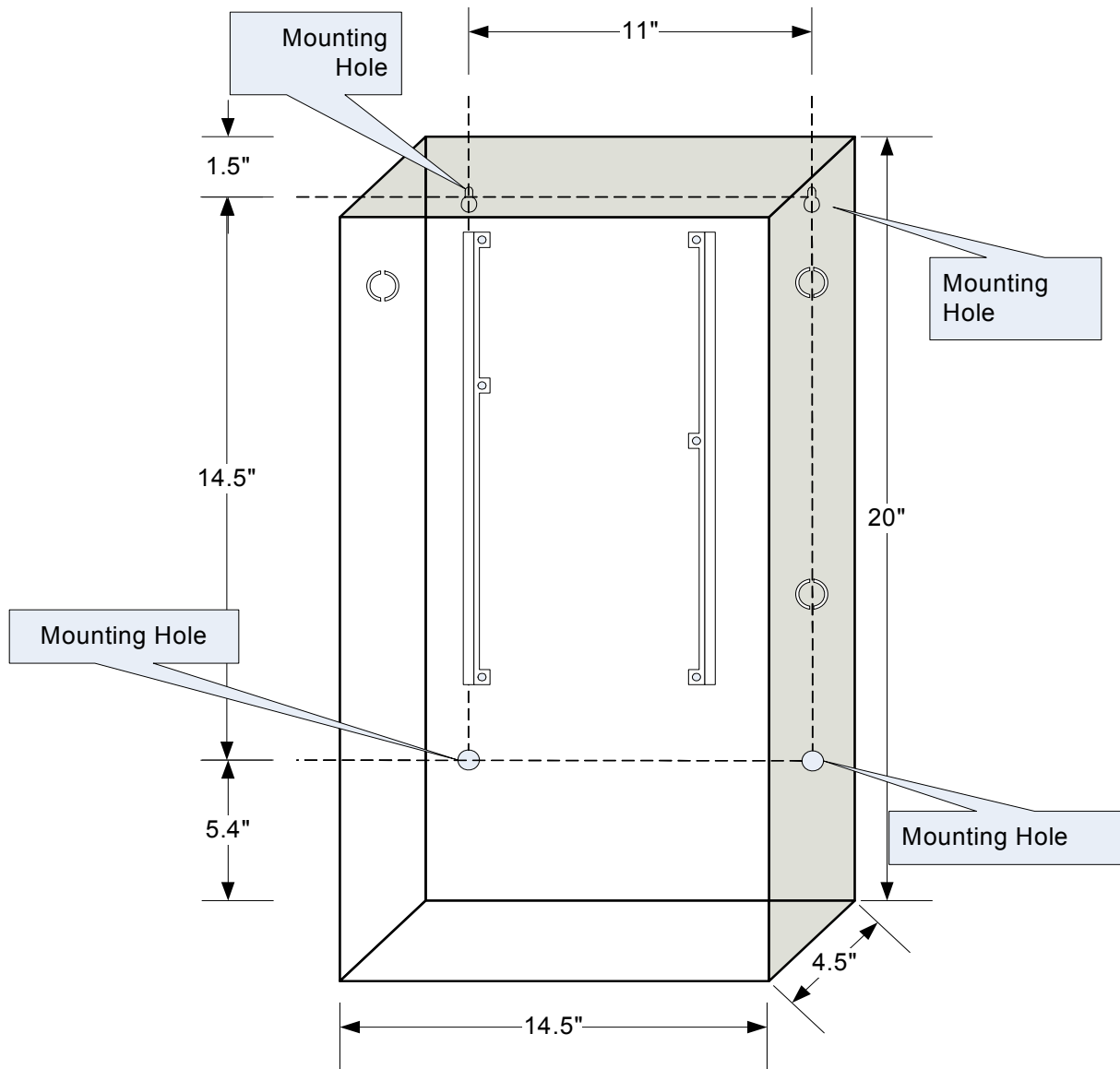
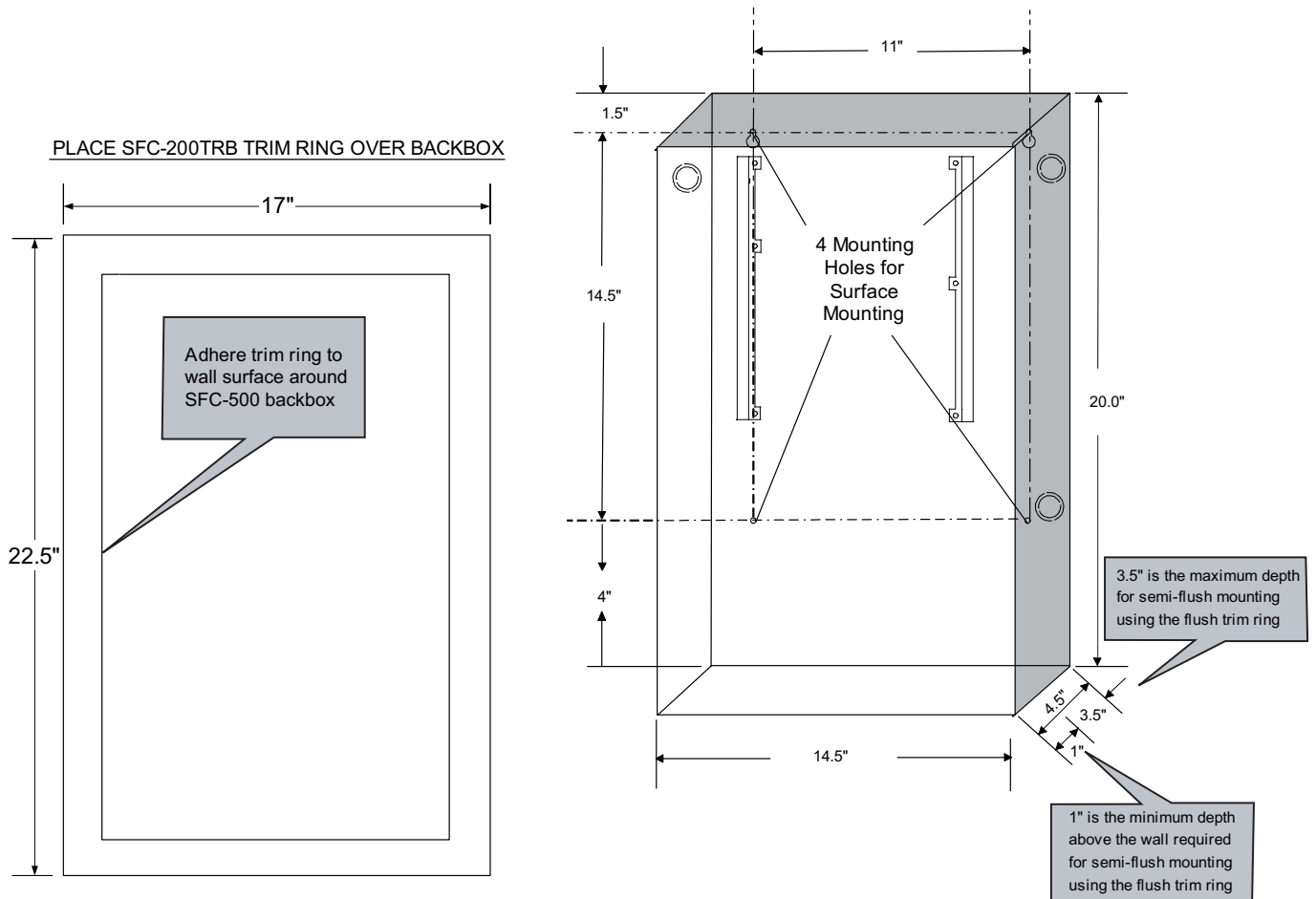
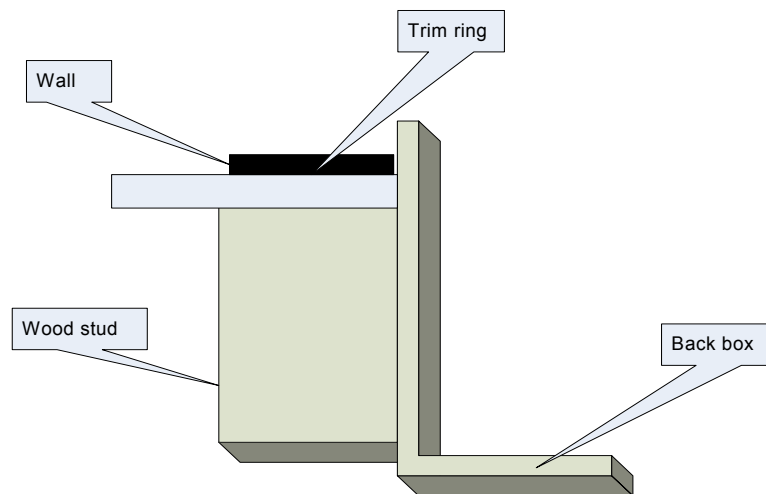

Figure 2: Mounting the SFC-500 - Flush



The figure below shows a cross-section of the semi-flush mounted backbox and the trim ring. **Make sure to allow a minimum depth of 1" above the wall surface for proper door opening.**

Figure 3: Flush Trim Detail



Installing Adder Modules

The SFC-500 Fire Alarm panels come pre-assembled with all components and boards except for Adder Modules. Module installation locations are shown below. Refer to **Figure 5** on the next page for Jumper or DIP Switch settings and see **Wiring Tables and Information** for wiring specifications.

Figure 4: Installation of Adder Modules

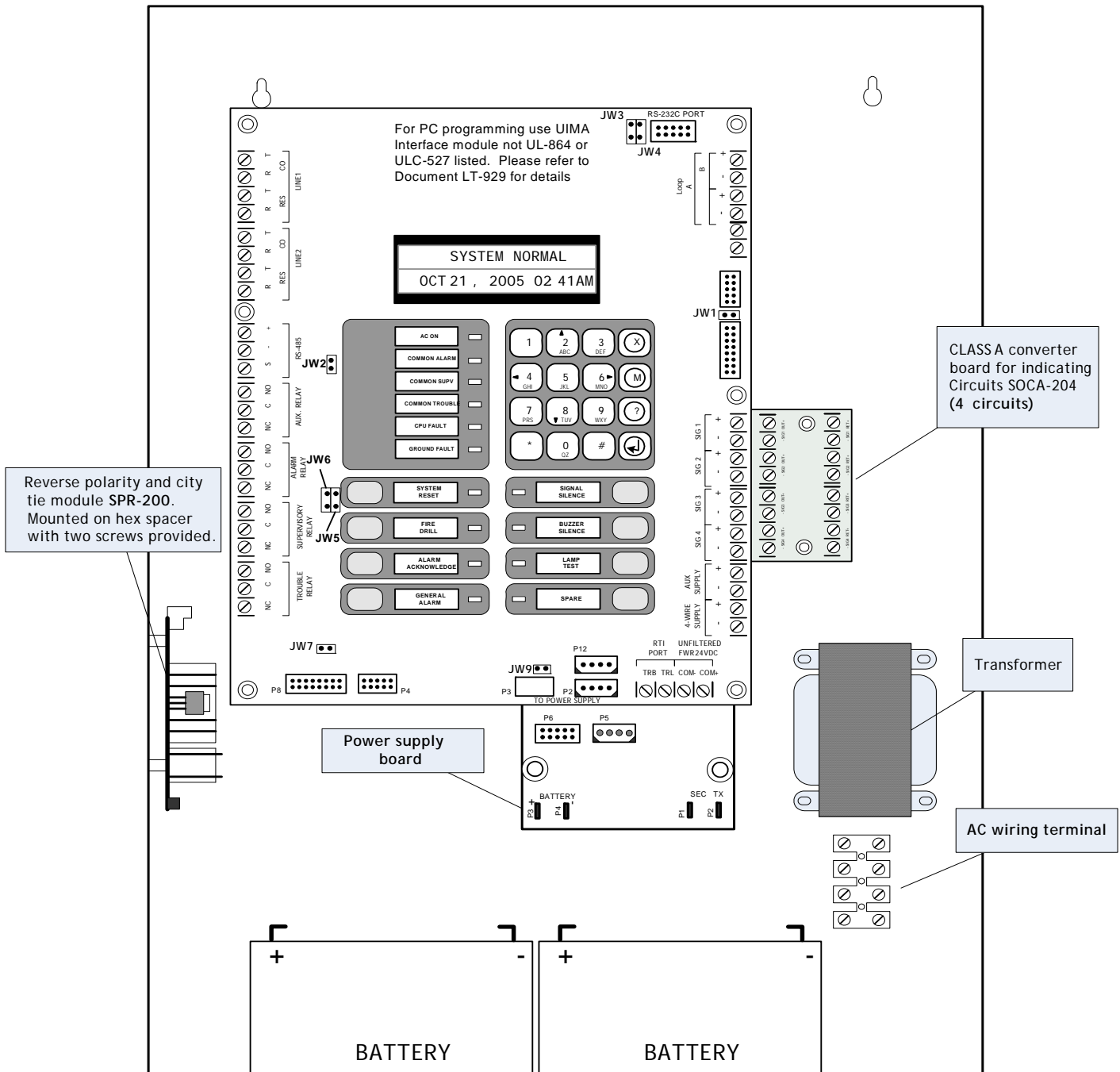

Cable and Jumper Connections for Main Board and Adder Modules

Figure 5: Main Fire Alarm Board Cable Connectors and Jumper Locations

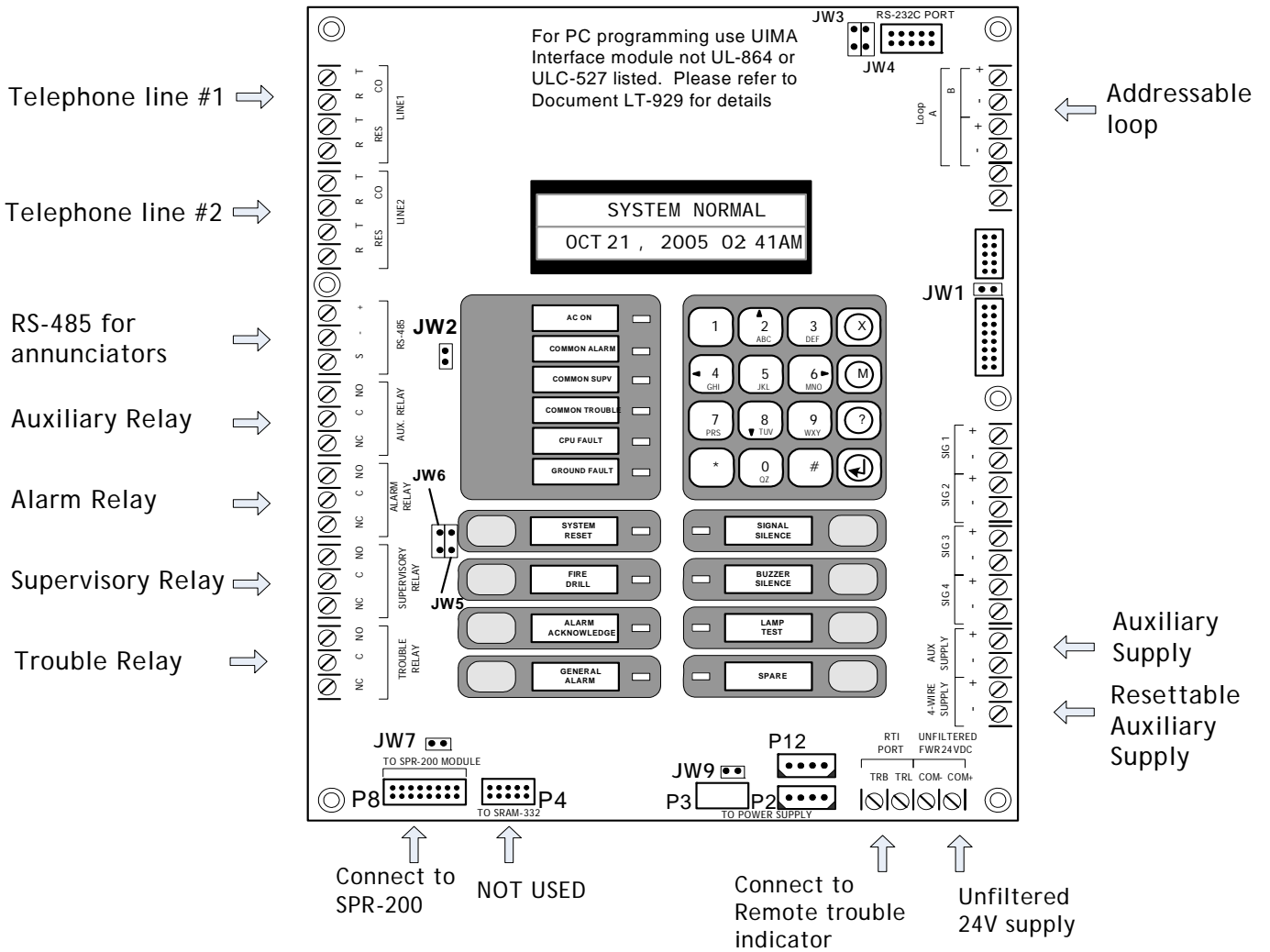
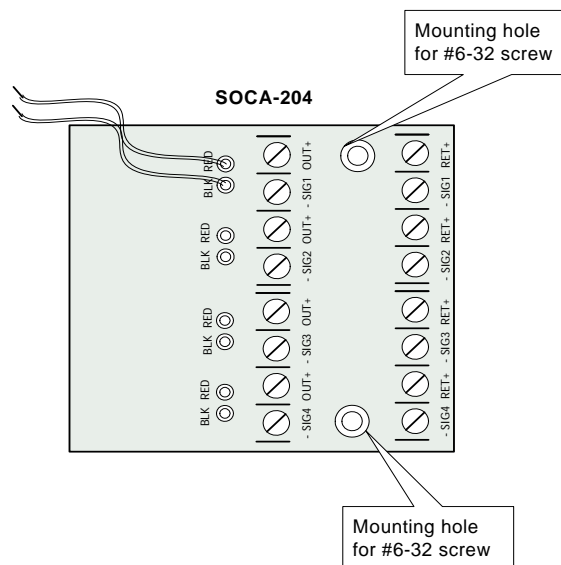

Table 1: Connectors and Jumpers on the Main Fire Alarm Board

P8	Cable from P1 of the SPR-200 Polarity Reversal and City Tie Module connects here. Otherwise not used.
P4	not used.
JW1	On the Main Fire Alarm Module, this jumper is not used, open.
JW2	Remove this jumper if a remote annunciator is used.
JW3	Not used, open.
JW4	Not used, open.
JW5	Normally open. Place jumper here and power down (AC and batteries) and power back to restore Master Passcode. After reset, remove jumper and leave normally open.
JW6	Normally open to BLOCK <u>remote</u> configuration via modem. Place jumper here to ALLOW for modem configuration.
JW7	On the Main Fire Alarm Module, this jumper must be removed if a SPR-200 Polarity Reversal and City Tie Module is installed.
JW8, JW9, JW10, JW11, JW12	Not used, open.

SOCA-204 Output Class A Converter Adder Module

Figure 6: SOCA-204 Output Class A Converter Adder Modules



Indicating circuits must be wired from the SOCA-204 to the main Fire Alarm board. For example indicating circuit 1 positive (red wire) and negative (black wire) is wired from the Class A Converter Module to the positive and negative terminals of Indicating circuit 1 on the Main Fire Alarm board.

The actual indicating zone is wired from the SIGNAL OUT positive and negative to the signaling devices and then wired back to the SIGNAL RET positive and negative.

Polarity Reversal and City Tie Module (Model SPR-200)

Mount the SPR-200 on the left side panel of the backbox with the two screws provided, refer to Figure 4.

Figure 7: Polarity Reversal and City Tie Module

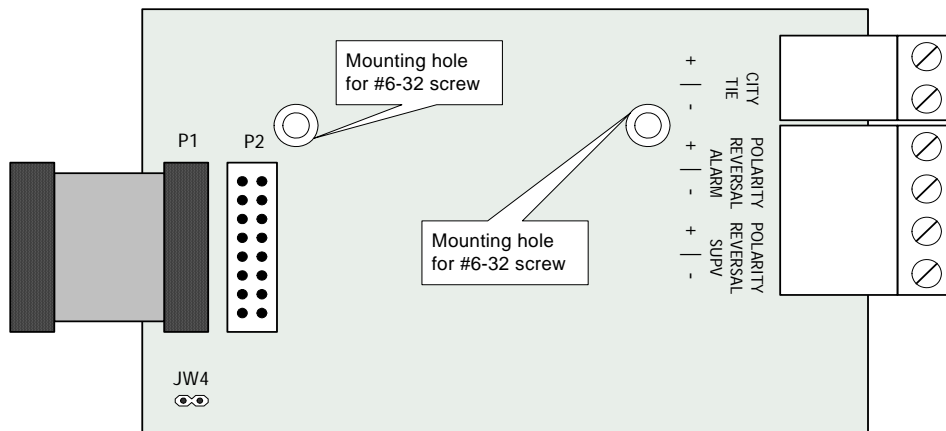

The following hardware configuration must be performed before installing the SPR-200.

Table 2: SPR-200 Cable and Jumper Settings

ITEM	SETTING
P1	Cable connects to P8 (bottom left-hand corner) on the Main Fire Alarm Board .
JW4	Not used with SFC-500. Keep Jumper intact.

The Alarm Transmit signal to the SPR-200 can be programmed to turn OFF when signal silence is active. This allows the City Tie Box to be manually reset. On subsequent alarms the silenceable signals will resound and the City Tie Box will be retriggered.

The Trouble Transmit signal to the SPR-200 can be programmed to delay AC power fail 0, 1, 2, or 3 hours if this is the only system trouble.

Circuits and Devices

Addressable/Analog Devices

The SFC-500 supports one loop of addressable/analog devices. The device loop can be used to connect up to 60 or 126 analog devices and addressable input or output modules on an unshielded twisted pair (UTP). The devices must be compatible with the Summit device protocol.

The loop interface software continuously supervises the devices on its loop against those found during configuration for the following conditions:

- device missing
- unconfigured device responding
- two or more devices responding to the same address
- wrong device type

A communication or addressing error on a device is reported as a trouble on the associated zone LED if configured.

The addressable loop can be configured for class A or B operation. "T-tapping" is allowed (Refer to device installation documentation for details). A short or open on the loop will activate the common trouble sequence with a latching trouble.

Devices on the loop have an optional LED which normally flashes when the device is polled and goes ON steady when the device is active (alarm for an input device or active for an output device). The flashing of the LED on polling for sensors can be suppressed during configuration. For input or output modules, the LED always flashes when polling. The software limits the maximum number of the devices which can have their LED turned ON when active to fifteen (15).

Certain devices are designed to support an optional external LED, which operates when the LED on the device is activated. Remote/external LEDs must NOT be used on this system. The panel can provide up to 350mA of current to the devices on the loop. A maximum line loss of 5 volts is permitted, so the loop distance, wire size, and maximum number of devices are limited by this constraint. The device currents are as follows:

DEVICE CURRENTS (uA)			
Device	Quiescent	Alarm	Inrush
Ionization	280	2280	1000
Photoelectric	340	4340	1000
Multi-sensor	470	3470	1000
Heat	250	2250	1000
Priority Switch Monitor	600	4600	2500
Mini Priority Switch Monitor	600	4600	2800
Single Relay Output	850	4850	3500
Supervised Output	1000	1000	6000
Isolator	35	35	0

The devices should be installed using unshielded twisted pair (UTP). The currents above may be used to calculate the total line drop on the loop, which must not exceed 5 volts worst-case at the last device. The calculations required to determine the maximum permissible loop wiring distance with various combinations of devices is relatively complicated, and when isolators are used, includes a consideration of device inrush currents which must not exceed 20mA for a single isolator. In no case should more than twenty devices be connected to a single isolator. To simplify the calculation process, please utilize the loop calculator program located on the Summit website at <http://www.summit-st.net> in order to determine maximum loop lengths, number of devices, and wire sizes etc.

It is also important to note that the device LEDs present a significant extra load on the loop which must be considered in calculating permissible loop lengths, battery capacities, etc. Please refer to the device Installation

Instructions and other documentation provided with the addressable devices, bases, and isolators for further information. **The system will automatically limit the maximum number of device LEDs which can be illuminated to 15.**

Analog Devices

The system supports Summit SI-200 Series photo, ion, and thermal (heat) type analog detectors, as well as contact input and output devices. The detectors may be configured as non-verified or verified alarm inputs. To determine an alarm condition, the system polls the analog device and compares the analog value against stored thresholds for pre-alarm and alarm conditions.

A range of thresholds is provided for each type of analog device (except for contact devices), corresponding to the agency approved range of threshold for a particular device type. Each device can be individually configured to a value in the range of threshold for “day time” and one for the “night time” or after hours operation; i.e. a device may be configured to a low sensitivity for “day time” and high sensitivity at “night time”. The day time threshold will be used unless the after hours operation is active.

Drift Compensation

The SFC-500 will automatically adjust for gradually increasing affects of dust and other accumulations of dirt in the detectors. It will adjust the thresholds to compensate for a detector going dirty according to the gradual change in the normal clean air value received. When it can no longer compensate for an increasingly dirty detector, a dirty detector trouble is indicated for that device.

Auto Test

Periodically each detector is commanded to return an alarm value to test its ability to alarm. If it fails the test, a trouble is indicated on that device. This trouble is latched until system reset.

Contact Inputs

Contact input modules on the addressable/analog device loop may be configured as any of the following input types:

- non-verified alarm inputs
- waterflow inputs
- non-latching supervisory inputs
- latching supervisory inputs
- monitor inputs
- trouble only inputs
- remote switch inputs

Contact Outputs

Contact output modules on the addressable/analog device loop may be configured as any of the following output types:

- signals
- strobes
- relay outputs

Analog devices may be installed with relay or sounder bases. The outputs of these bases are activated when the device active LED turns ON steady in response to an alarm. The command to activate the output is separate from the command that activates the LED and they are not subject to the same restrictions as the LED. **Output modules configured as signals are not stroked by software at the current signal rate.** When the system commands them to be either in alert or in evacuation, the panel will simply activate them continuously. It is possible to provide stroked operation by connecting the signal power to a conventional signal output which is stroking at the correct rate when the device is active. Depending on the device, the system can detect open and short troubles and report it as an output circuit trouble.

Field Wiring

Main Fire Alarm Board Field Wiring

Wire devices to the addressable loop as shown in Figure 8 for Class B (Style 4) or Figure 9 for Class A (Style 6). Refer to the Table 2 for loop wire gauges.

Figure 8: Addressable Loop Wiring - Class B or Style 4

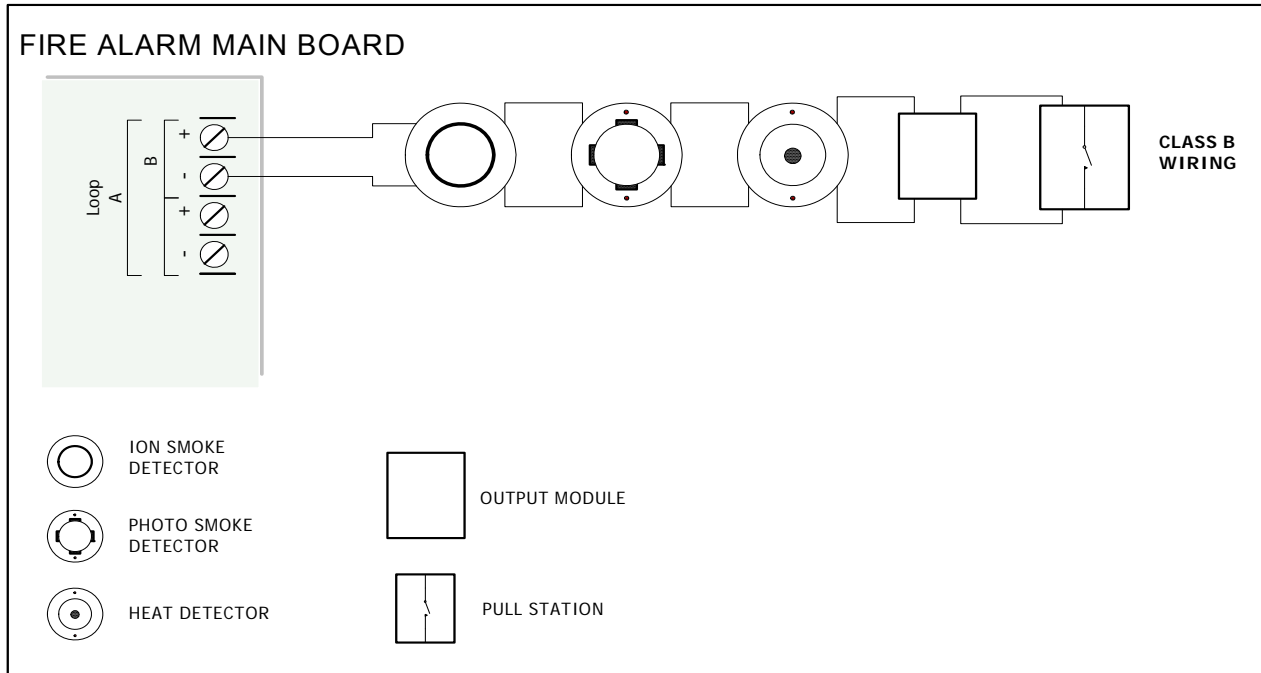

Table 2: Loop Wiring Table

UNSHIELDED TWISTED PAIR WIRE GAUGE	LOOP TOTAL (OUT AND IN) WIRE RUN	
	FEET	METRES
AWG		
12	20,000	6098
14	15,942	4859
16	9960	3036
18	6265	1910

This Loop Wiring Table is for reference only and should not be used without a detailed loop calculation.

Maximum Loop Current: 350 mA

Maximum Loop Resistance: 35 subtract 0.2 Ohms per isolator.

Maximum Loop Capacitance: 0.5 uF

Maximum Number of Isolators is 40.

Loop Isolators

To limit the number of addressable devices compromised by a short on the addressable loop, isolators (SIM-100X, 100XH, or 100XB) may be used to isolate the affect of the short circuit. If the impact of a short circuit must be limited to only one device, an isolating base must be used for each detector. A maximum of twenty devices can be connected between isolators, or between the panel and the first isolator, as long as the maximum in-rush current for the devices on one segment of the loop does not exceed 20mA. Refer to the installation instructions for

addressable devices for additional details.

Figure 9: Addressable Loop Wiring -Class A or Style 6

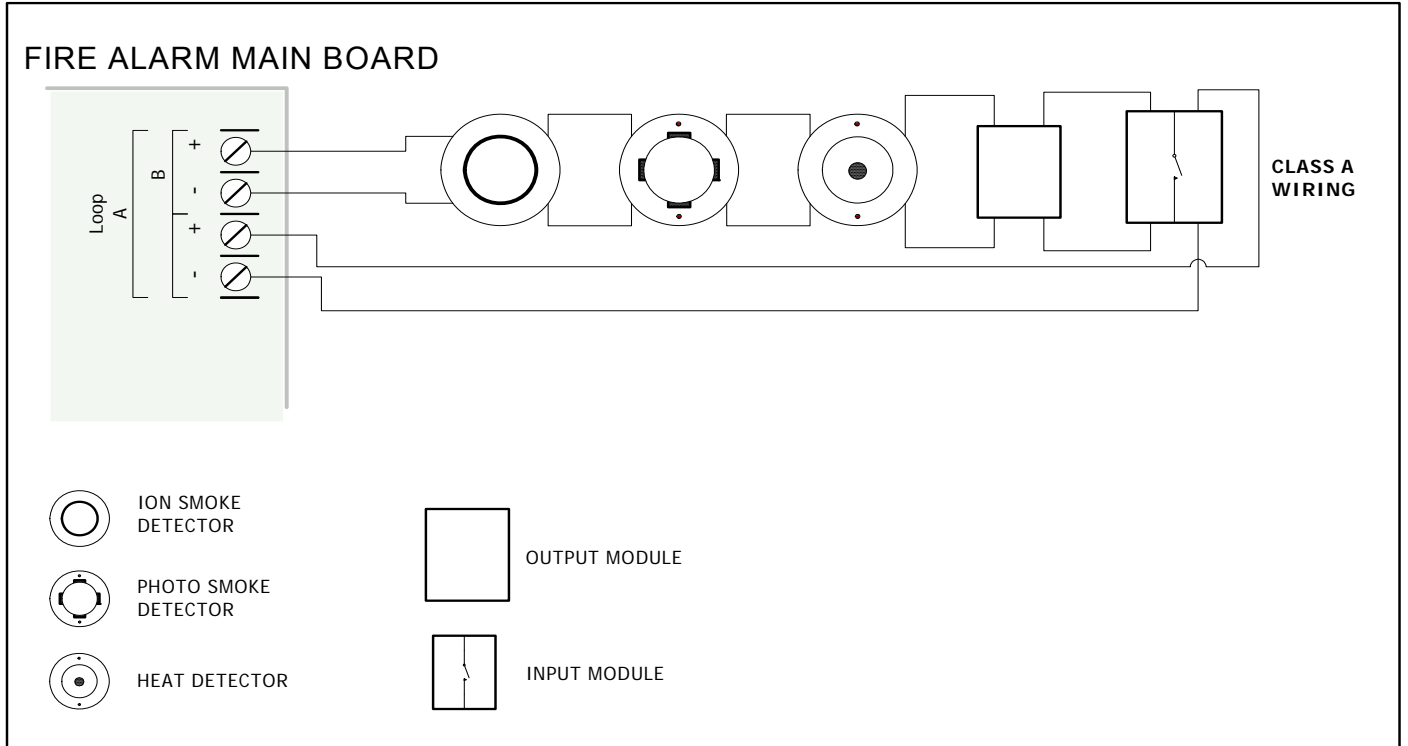

Loop Operation

When there is a short circuit on the Class A loop with isolators installed, the isolators isolate the shorted fault, the panel detects it as an open loop and generates an open loop trouble.

When a Class A loop is opened there may be a few missing devices reported by the panel which will be restored once the panel has established the Class A connection.

Note: When there is an "Open loop trouble" look for both open and shorts on the loop. As a guideline the isolators which are activated in response to a short will have their LED ON; look for the short between the two isolators with their LEDs ON.

Indicating (Powered Output) Circuits

Powered output circuits can be configured as signal, strobe or relay outputs. Powered output circuits are supervised while they are not active for both open circuits and shorts. The circuit will not actually be activated if there is a short trouble on the circuit. It will be activated if an open trouble is indicated. A circuit trouble activates the common trouble sequence as a non-latching trouble. Since open circuit supervision does not operate while the circuit is in alarm, if the circuit was in trouble before it was activated, it will still indicate trouble while active. The trouble condition will be re-evaluated when supervision resumes.

Output circuits configured as strobes can have sync protocol for synchronization if configured. Certain strobe and strobe/horns models of the following manufacturers are supported.

1. All normal non-synchronized horns
2. Faraday
3. System Sensor
4. Wheelock
5. Gentex (Secutron)
6. Mircom

When configured as normal, the output circuit is ON continuously when activated and does not use any sync protocol. When configured as non-silenceable strobes, the strobes cannot be silenced, but the horn can be silenced by pressing the 'signal silence' button

If the strobe is configured as silenceable strobe both the horn and the strobe are silenced (stopped) by pressing the 'signal silence' button

Indicating Circuit Wiring

The SFC-500 Addressable Fire Alarm Panel supports Class B (Style Y) and Class A (Style Z) wiring for its indicating circuits. Each circuit is supervised by a 3.9K End-of-Line resistor. Each indicating circuit provides up to 1.7Amperes, total 5Amperes of current maximum if no auxiliary power is used. Wire indicating circuits as in Figure 11 for Class B (Style y) or as in Figure 12 for Class A (Style Z).

Table 3: Indicating Circuit Wiring

Total signal load in amperes	Maximum wiring run to last device								Max loop resistance in ohms
	18 AWG		16 AWG		14 AWG		12 AWG		
	Feet	Meters	Feet	Meters	Feet	Meters	Feet	Meters	
0.06	2350	716	3750	1143	6000	1829	8500	2591	30
0.12	1180	360	1850	567	3000	915	4250	1296	15
0.3	470	143	750	229	1200	366	1900	579	6
0.6	235	71	375	114	600	183	850	259	3
0.9	156	47	250	76	400	122	570	174	2
1.2	118	36	185	56	300	91	425	129	1.5
1.5	94	29	150	46	240	73	343	105	1.2
1.7	78	24	125	38	200	61	285	87	1.0



Notes:

- For Class A wiring the resistance in ohms is multiplied by two.
- Maximum voltage drop should not exceed 1.8 volts.

Figure 10: Indicating Circuit – Class B or Style Y Wiring

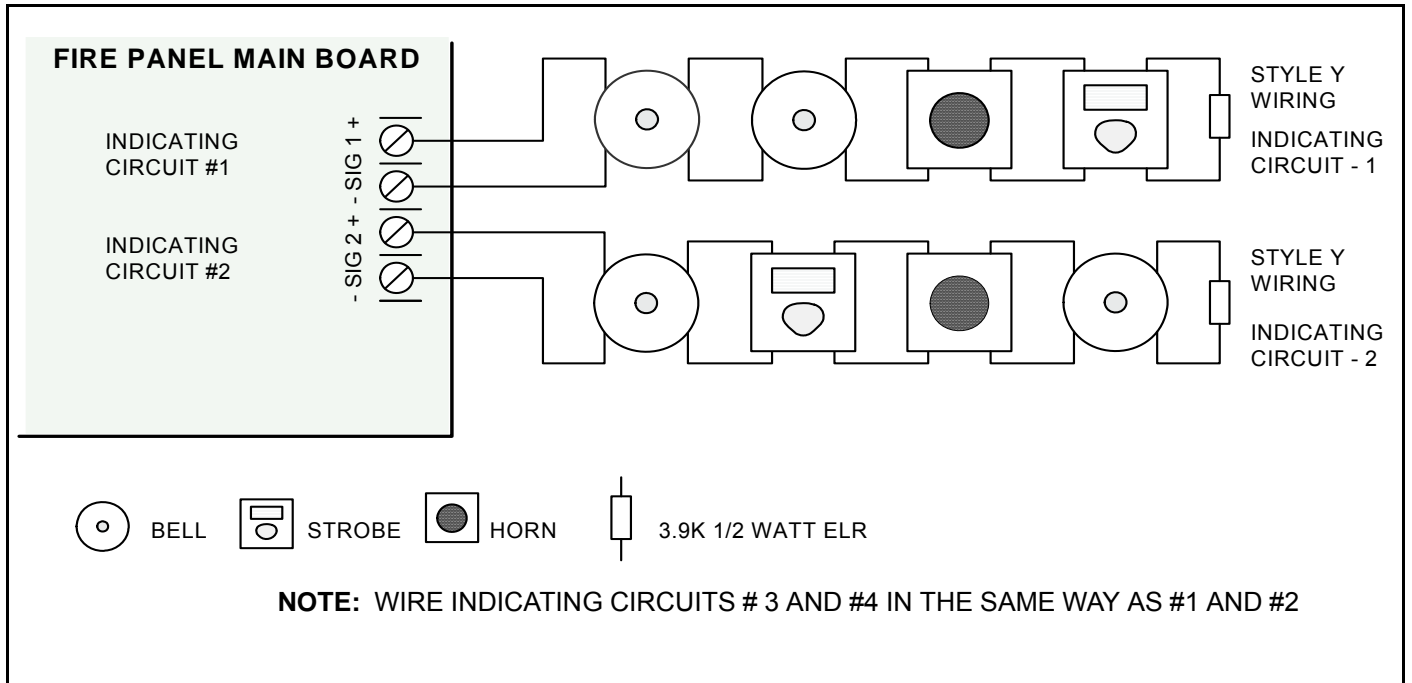
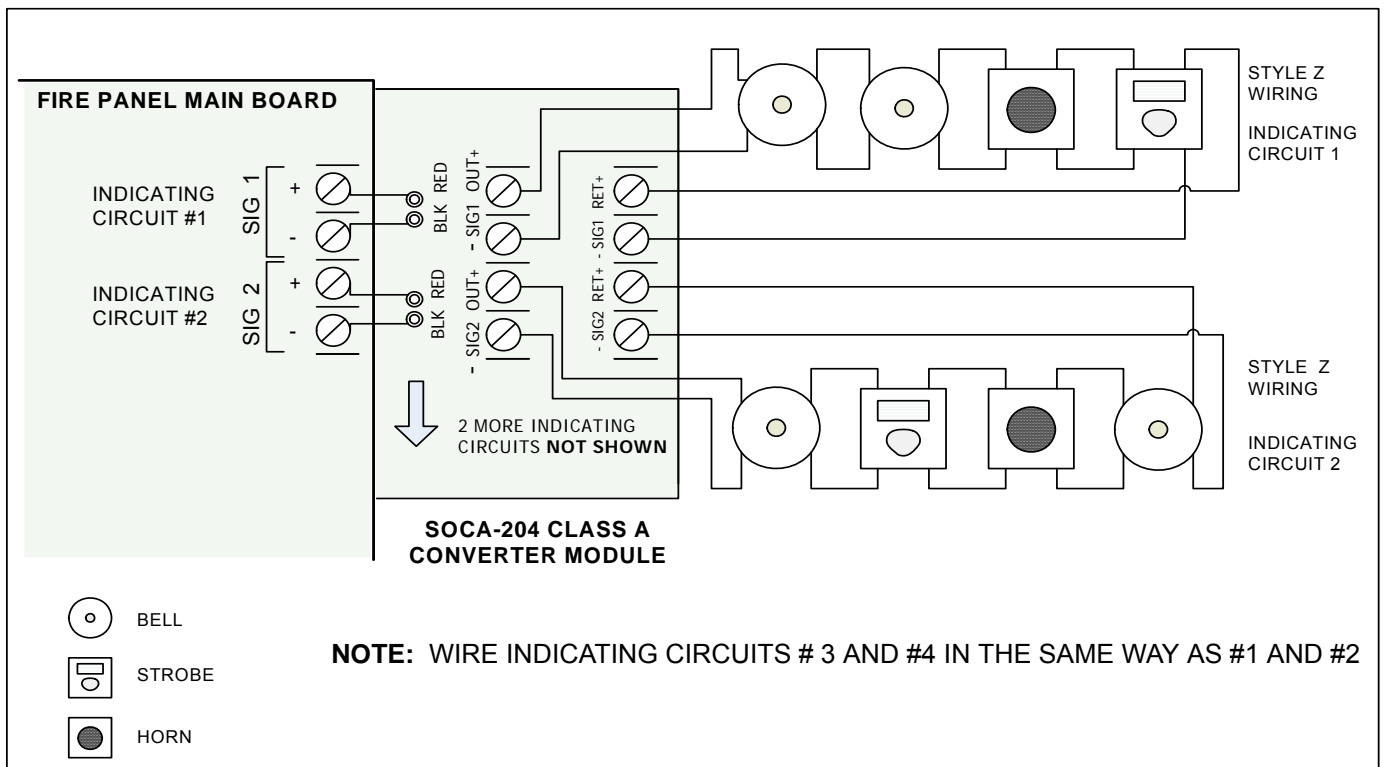

Figure 11: Indicating Circuit –Class A or Style Z Wiring



Dialer Wiring

If you have Fire Alarm Panel model **SFC-500-60-DR** and **SFC-500-126-DR**, there is a dialer on board and terminals marked Line 1 and Line 2 must be wired as shown in Figure 12 below. Terminals are located in the top left hand corner of the main fire alarm board, from the top down. Refer to Figure 5 for terminal location.

Figure 12: Dialer Wiring

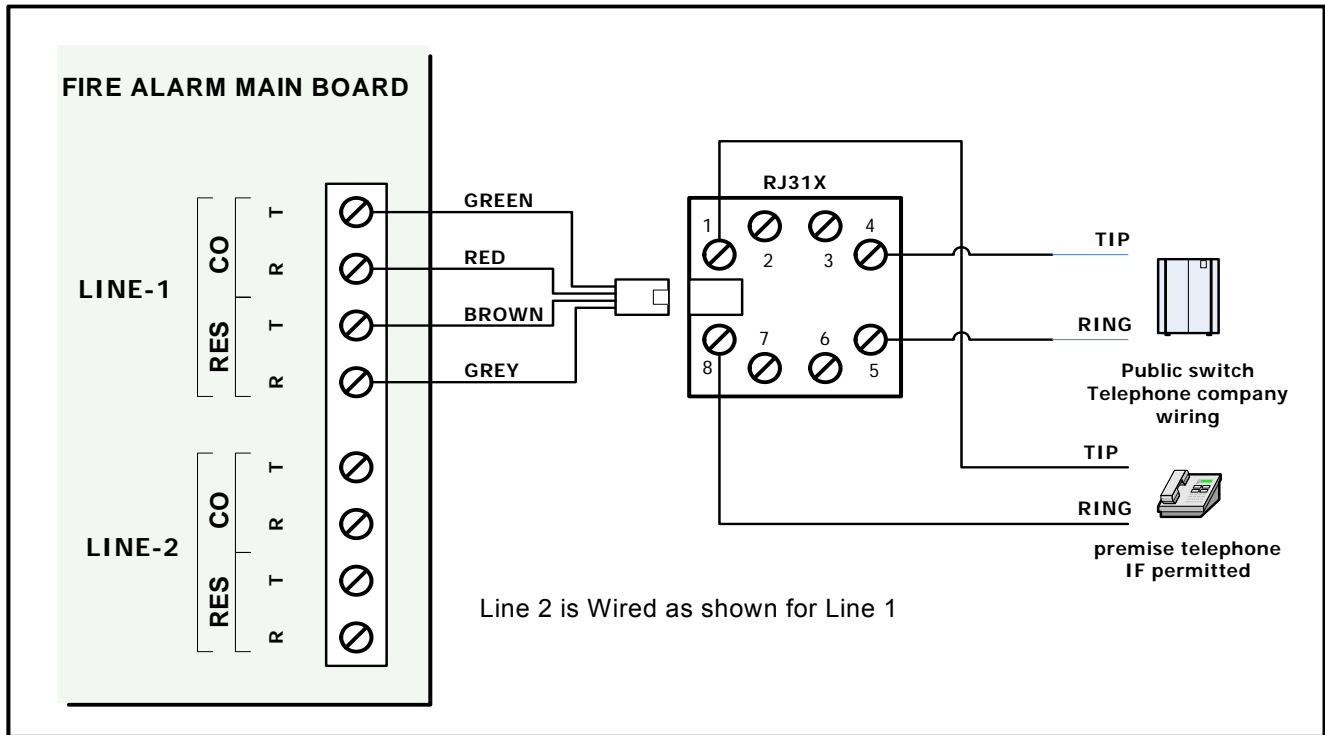

Refer to Dialer Operation Section and Appendix B for more information regarding the built-in dialer.

Polarity Reversal and City Tie Module (SPR-200) Wiring

Wire the SPR-200 Polarity Reversal and City Tie Module (if used) as shown in *Figure 13*, below. Power Limited cable type FPL, FPLR or FPLP must be used. For USA installation, the installer must use **Atlantic Scientific (Tel: 407-725-8000), Model #24544 Protective Device**, or similar **UL-Listed QVRG secondary protector**, as shown. For use in Canada, the Protective Device is not required but still recommended.

Figure 13: Polarity Reversal and City Tie Module Terminal Connection

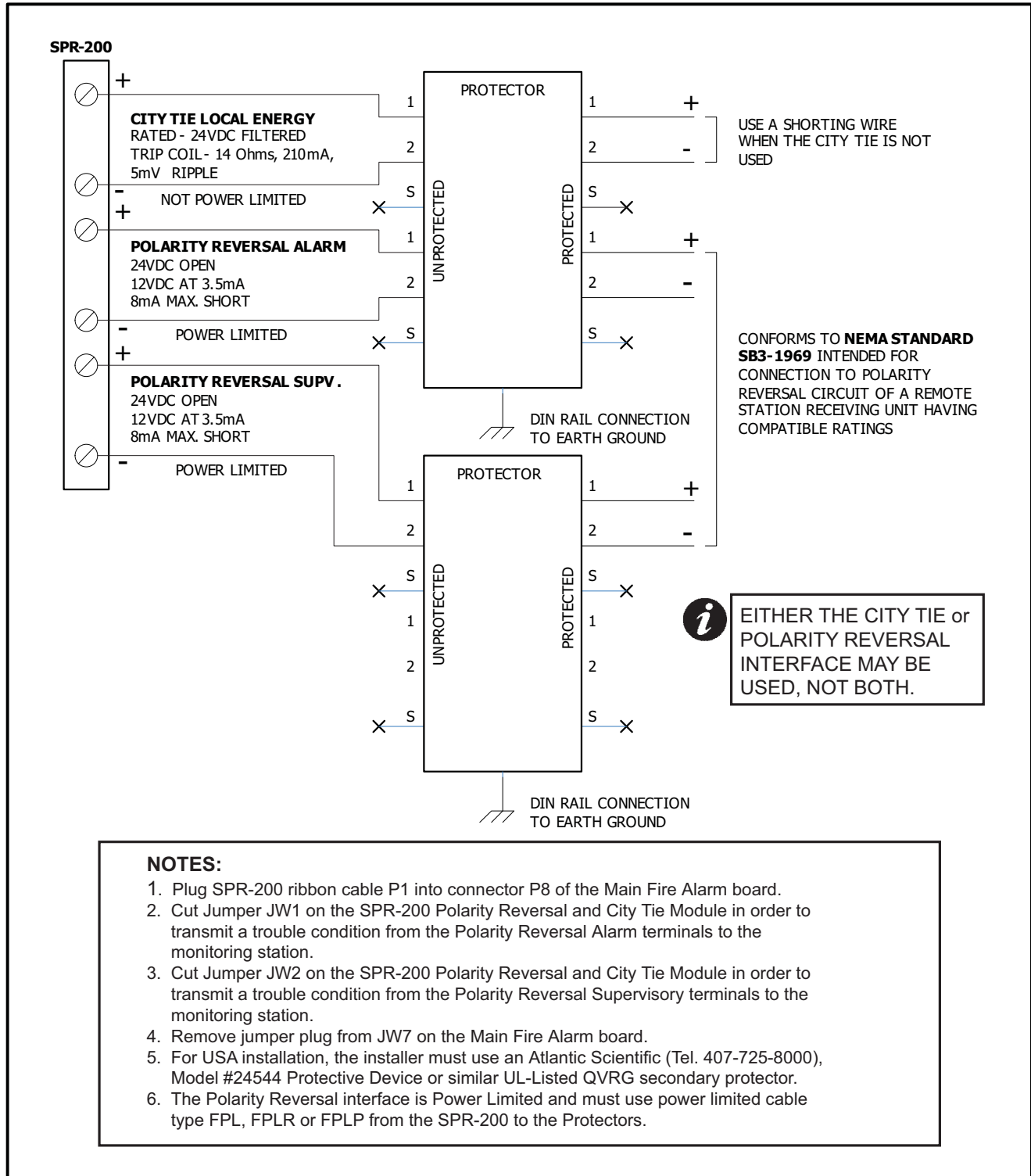

Auxiliary Power Supplies

Aux 2 Resettable Auxiliary Power (supervised, regulated)

The AUX 2 resettable auxiliary power supply is supervised for shorts, therefore a short will disconnect the power until the "RESET" button is pressed. A trouble signal will be generated if there is a short. The circuit must be supervised for opens utilizing the End of Line Relay Model PAM-3 as shown in Figure 15. This supply is rated at 21.1VDC regulated/300mA max/1V voltage drop maximum.

Auxiliary Supply (supervised, regulated)

Supervised auxiliary power is used to power the remote annunciators and smart relay modules. This filtered circuit is supervised for shorts, therefore a short will disconnect the power until the "RESET" button is pressed. A trouble signal will be generated if there is a short. The circuit must be supervised for opens utilizing the End of Line Relay Model PAM-3 as shown in Figure 15. This supply is rated at 21.1VDC regulated/500mA max/1V voltage drop maximum.

Unfiltered Supply (unsupervised, unregulated)

This unregulated supply is not supervised. When required, it is recommended that the circuit be supervised for opens utilizing the (UL listed - S3403) End of Line Relay Model PAM-3 as shown in Figure 14. This supply is rated at 24VDC/1.7A max. If there is a short on this circuit, the auxiliary power does not recover automatically when the short is removed. The main power and the battery must be disconnected, then reconnected and the panel reset to re-establish the auxiliary power supply.

Figure 14: Supervision Of Auxiliary Supplies

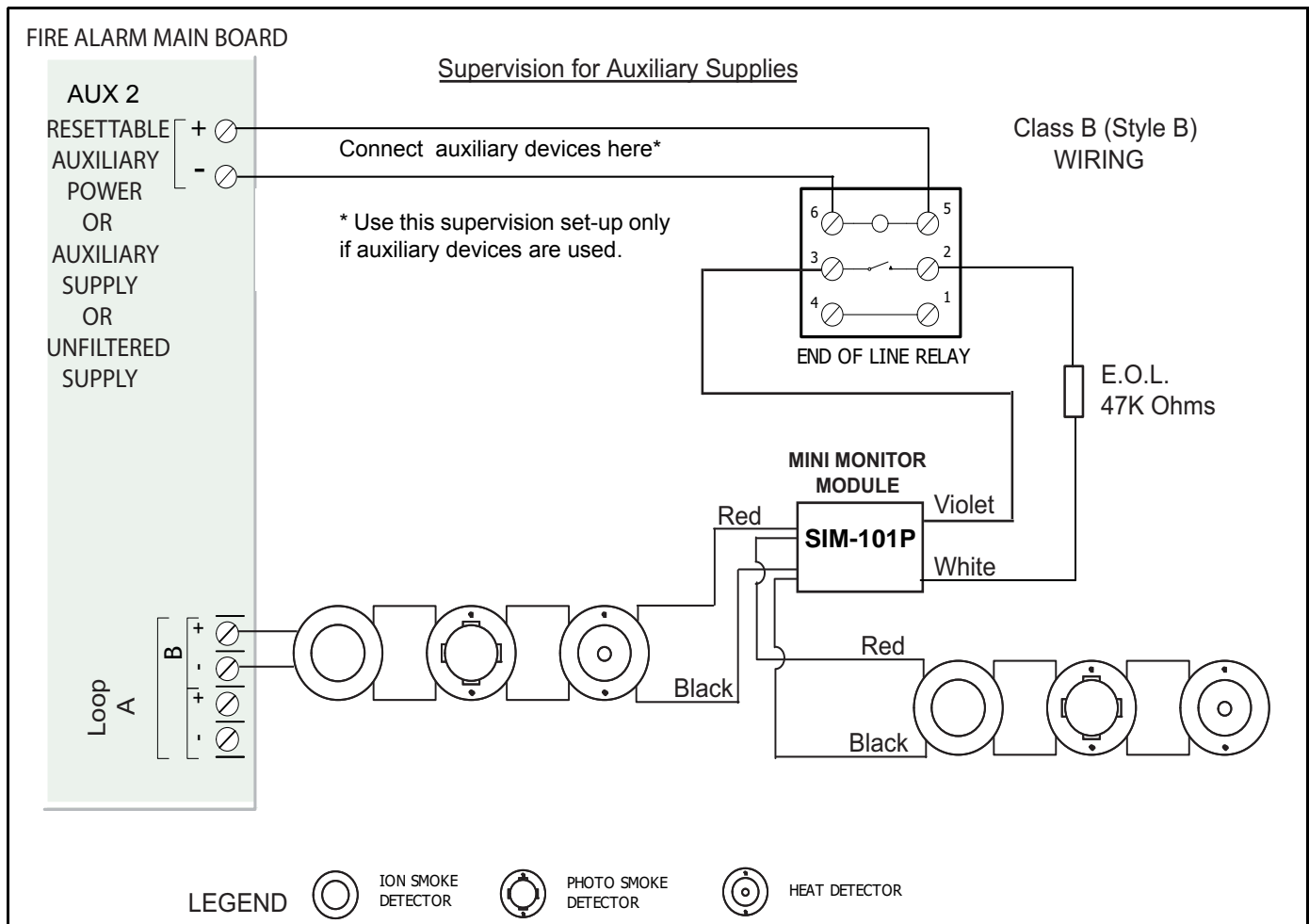

Power Supply Connections

The power supply is located directly behind and below the main board. The ratings are:

TYPE	RATING
Electrical Input rating	120 VAC, 60Hz, 1.73A / 240VAC, 50Hz, 0.864A
Battery fuse on Main module	10A, slow blow micro fuse (not replaceable)



Caution: The main AC branch circuit connection for the Fire Alarm Control Unit must provide a dedicated continuous power without any disconnect devices. Use #12 AWG wire with 600-volt insulation and proper over-current circuit protection that complies with the local codes. Refer to Appendix C for specifications.



Note: Ensure that the AC supply is disconnected before wiring the power to the panel. Wire the AC power to the AC wiring terminals as shown in Figure 16 using the proper wire gauge. Fire alarm systems must be installed in compliance with local codes and standards and with the Authority Having Jurisdiction (AHJ)

Figure 15: Main Power Supply Connections

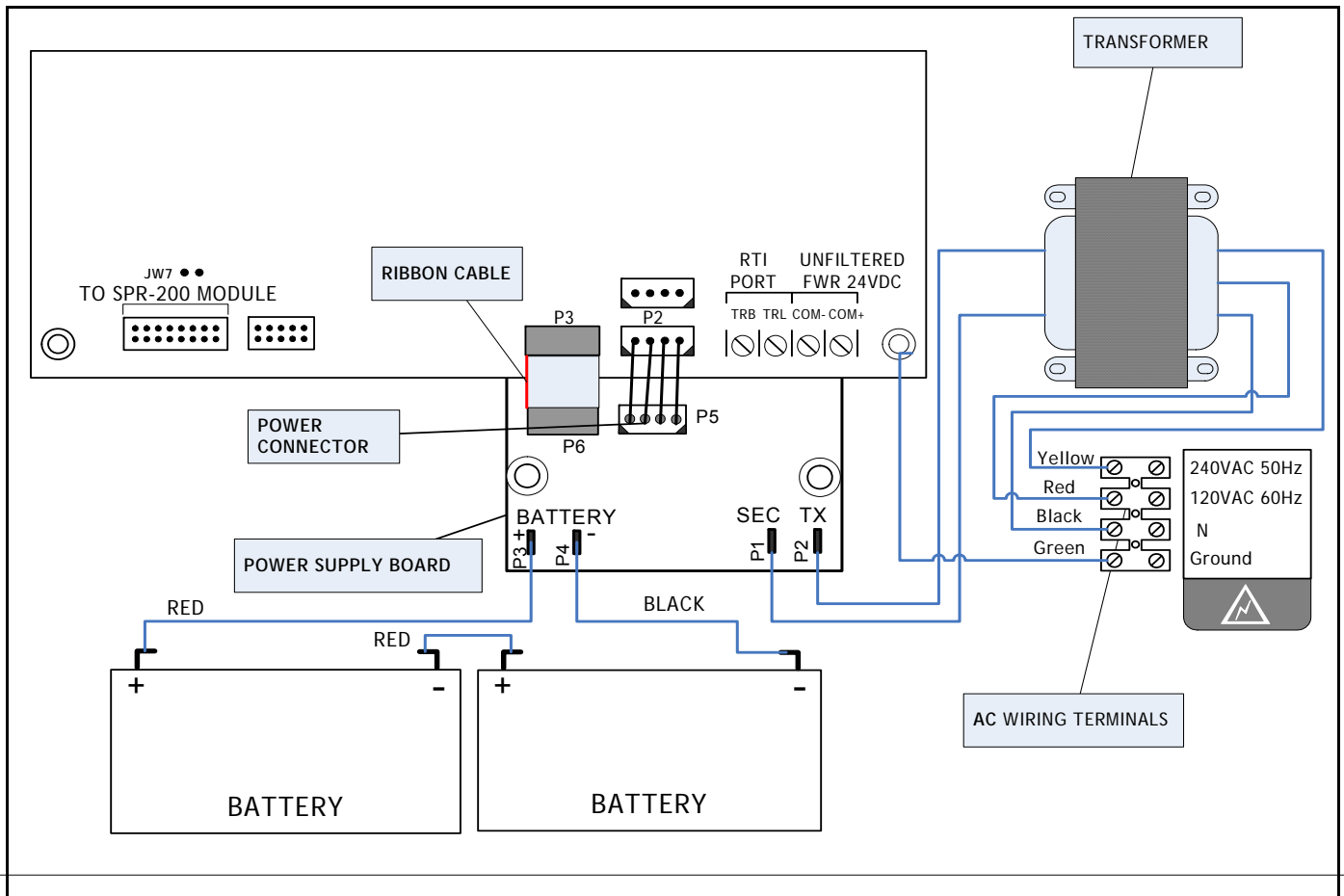

Note: The SFC-500 panel is capable of being wired for 120 VAC or 240 VAC 50/60 Hz as shown above. A good ground connection to the “Ground” terminal is essential to electrical safety, ensure proper operation, and specified noise immunity.

System Checkout

Before turning the power "ON"

To prevent sparking, **do not connect** the batteries. Connect the batteries after powering the system from the main AC supply.

1. Check that all adder modules are installed in the proper location with the proper connections.
2. Check all field (external) wiring for opens, shorts, and ground.
3. Check that all interconnection cables are secure, and that all connectors are plugged in properly.
4. Check all jumpers and switches for proper setting.
5. Check the AC power wiring for proper connection.
6. Check that the chassis is connected to earth ground (cold water pipe).
7. Make sure to close the front cover plate before powering the system from main AC supply.

The best way to set up a panel for the first time is to avoid connecting any field wiring at first. To begin set up, power up the panel with end of line resistors connected where appropriate, then connect the battery. The panel will show "System Restart Active". Press System Reset button to reset the panel. If the panel is free of trouble, connect one circuit at a time, checking for troubles each time. If a trouble occurs at any point during the set-up, correct the fault, then continue connecting the field wiring.

Power-up procedure

After completing the system checkout procedures outlined above,

8. Power up the panel. The "AC ON" green LED and the "Common Trouble" LED should illuminate, and the buzzer should sound. Press the "System Reset" button. Since the batteries are not connected, the trouble buzzer should sound intermittently and the common trouble LED should flash.
9. Connect the batteries while observing correct polarity: the red wire is positive (+) and black wire is negative(-). All indicators should be OFF except for normal power "AC ON" green LED.
10. Configure the Fire Alarm Control Panel as described in the System Configuration section.

Troubleshooting

Symptoms	Possible Cause
Circuit Trouble	Normally when a circuit trouble occurs, its designated trouble indicator will be illuminated, as well as the common trouble indicator and trouble buzzer. To correct the fault, check for open wiring on that particular circuit loop or that the Circuit Disconnect Switch is in the ON or CLOSED position. Note: Disconnecting a Circuit will cause a system trouble (off-normal position).
Remote Trouble	Remote Trouble will be indicated on the main panel display for any failure reported by, or failure to communicate with a remote annunciator or other remote device.
Ground Fault	This panel has a common ground fault detector. To correct the fault, check for any external wiring touching the chassis or other Earth Ground connection.
Battery Trouble	Check for the presence of batteries and their conditions. Low voltage (below 20.4V) will cause a battery trouble. If battery trouble condition persists, replace batteries as soon as possible.
Walk Test Mode	If the Walk Test LED is illuminated steadily, the system is in Walk Test Mode.
Common Trouble	If only a common trouble is indicated on the main panel and none of the above confirming trouble indicators are ON, check the following for possible fault: <ul style="list-style-type: none"> • Check for any missing interconnection wiring. • Check for any Module missing that was part of the Configuration. • Check for improperly secured cabling.

Indicators, Controls and Operations

Figure 16 below shows the common display panel for the SFC-500 Fire Alarm Control Panel.

Figure 16: LCD Display, LED indicators and control buttons

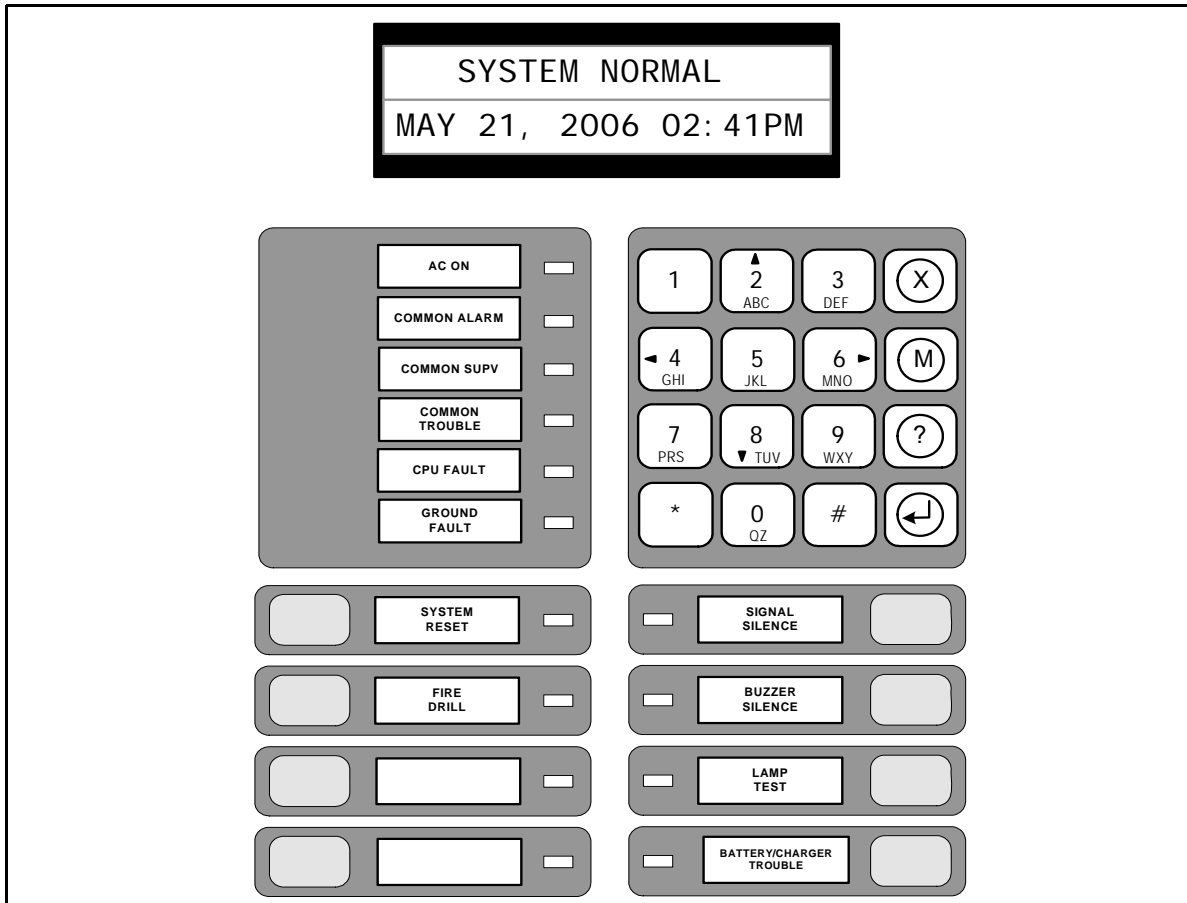

The display panel on the SFC-500 main fire alarm control board consists of:

- a two line by twenty character LCD display
- a sixteen button keypad
- common LED Indicators
- common control buttons

LED Indicators may be amber, red, or green, and may illuminate continuously, or at one of following Flash Rates:

- **Steady (Alarm) - ON continuously.**
- **Fast Flash (Supervisory) - 120 flashes per minute, 50% duty cycle.**
- **Trouble Flash (Trouble) - 20 flashes per minute, 50% duty cycle.**

Red indicators are used for Alarm, amber indicators for Trouble or Supervisory and green for power ON.

Common Indicators

Buzzer

The Buzzer is activated by any of the following:

- **Fire Alarm:** Steady
- **Supervisory Alarm:** Fast flash rate
- **Trouble:** trouble flash rate
- **Monitor:** Configurable to sound at trouble flash rate

If the buzzer turns ON in response to a non-latching trouble or supervisory, it will turn OFF if the condition causing it goes away and there is no other reason for it to be ON.

AC On LED

The AC On LED illuminates steady green while the main AC power is within acceptable levels. It turns off when the power level falls below the power-fail threshold and the panel switches to standby (battery) power.

Common Alarm LED

The Common Alarm LED illuminates steady red whenever the panel is in alarm. An alarm results from any alarm on any point or input programmed as alarm or activation of the manual General Alarm button (if the panel is set for two stage operation). Since all alarms are latched until the alarm conditions are cleared and the panel is reset, the LED will remain ON until then.

Common Supervisory LED

The Common Supervisory LED flashes amber at the Supervisory or Fast Flash rate when there is a supervisory alarm in the panel resulting from any un-bypassed latching or non-latching supervisory circuit. The LED turns OFF if all non-latching Supervisory Circuits are restored and there are no active latching supervisory circuits. Latching supervisory alarms remain active until the panel is reset.

Common Trouble LED

The Common Trouble LED flashes amber at the Trouble Flash rate when the panel detects any trouble condition in the system. The LED turns OFF once all non-latching troubles are cleared.

CPU Fault LED

The CPU Fault LED flashes amber at the Trouble Flash rate when the panel detects a fault on the CPU. It is turned OFF when the CPU fault is corrected.

Ground Fault LED

The Ground Fault LED flashes amber at the trouble flash rate when the Ground Fault Detector detects a ground fault on any field wiring. It turns off immediately after the ground fault is cleared.

System Reset LED

The amber System Reset LED will illuminate steadily after the system reset button has been pressed and the system is resetting.

Signal Silence LED

The Signal Silence LED flashes amber at the Trouble Flash rate after indicating circuits are silenced either by the Signal Silence button, or by the Auto Signal Silence Timer. It turns OFF after the signals are re-sounded by a subsequent alarm.

Fire Drill LED

The Fire Drill LED turns ON steady amber while Fire Drill is active.

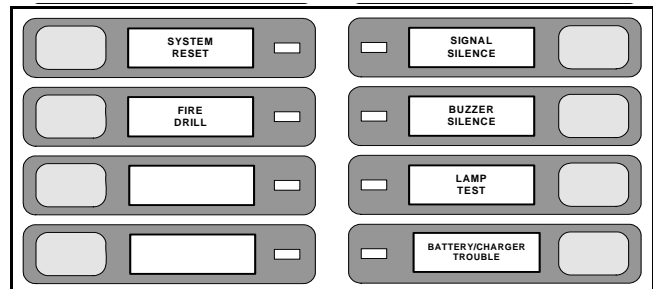
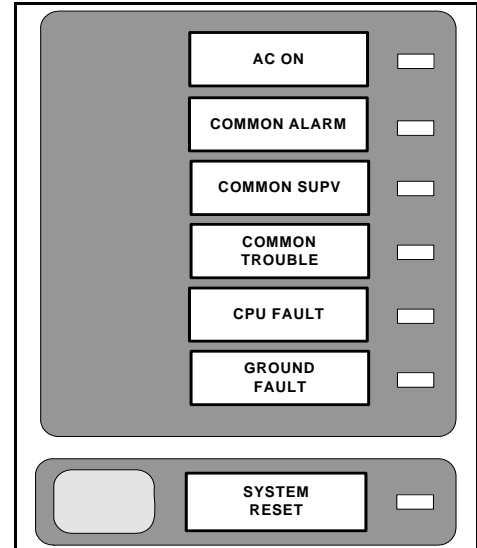

Lamp Test LED

The amber Lamp Test LED will illuminate steadily after the Lamp Test button is pressed and while system is in Lamp Test mode.

Common Controls

LCD Display

The display is a two line, 20 character back-lit alphanumeric LCD. It displays information regarding the panel, its circuits, and devices. An on-screen cursor is controlled by the cursor buttons (located to the right of the display) for menu selection and control. Report information provided by the LCD display includes Alarm, Event Log, Current Levels, Verification, and Maintenance reports.

Cursor Buttons

Located at key number 2, 8, 6 and 4. The cursor buttons Up (next), Down (previous), Right, and Left allow you to select items on the LCD display. The Up and Down buttons scroll through lists in a continuous loop.

Enter Button

Use this button to select a displayed item on the LCD display.

Cancel Button

Use this button to cancel an operation or exit a menu.

Menu Button

Use this button to view the Command Menu.

Info Button

Push and hold this button to get detailed information about any displayed item.

Signal Silence Button

Pressing the Signal Silence button after the panel is in alarm turns ON the Signal Silence LED and de-activates any silenceable indicating circuits. Non-silenceable circuits are unaffected. Signals will re-sound upon any subsequent alarm. This button does not function during any configured Signal Silence Inhibit Timer period. It also does not function if indicating circuits are active as the result of a Fire Drill. This button acts as a toggle switch.

Fire Drill Button

The Fire Drill button activates all programmed and non-disconnected indicating circuits, but does not transmit any Alarms via the city tie or common alarm relay. The Fire Drill is cancelled by pressing the button again (toggle switch), or if the panel goes into a true alarm.

System Reset Button

The System Reset button resets the panel and all circuits:

- Resets all Latching Trouble Conditions
- Resets Auxiliary Resettable Power Supply
- Turns OFF Signal Silence LED
- Stops and resets all Timers
- Aux Disconnect is not affected
- Turns off all Indicating Circuits
- Turns off Fire Drill
- Processes inputs as new events
- Reset cannot be activated until the Signal Silence Inhibit timer has expired





ATTENTION: After power-up, press the System Reset button to bring the system to normal and restore the “system power up” trouble.

Lamp Test Button

Pressing and holding the Lamp Test button causes all front panel indicators to illuminate and sounds the buzzer steadily. Bi-coloured LEDs will illuminate twice to show both colors. If lamp test is active for more than ten seconds, the Common Trouble LED activates.

Operation

In a single stage system, all alarm inputs are treated in a similar manner. Alarm inputs include any of the following: non-verified alarm, verified alarm, waterflow alarm, and general alarm circuits. Any of these alarm inputs occurring when the panel is not already in alarm cause the following:

- The buzzer sounds steadily
- If fire drill is active, it is cancelled
- The Common Alarm LED turns ON
- The Common Alarm relay activates if Aux disconnect is not active
- The Auto Signal Silence timer, if configured, starts
- The Signal Silence Inhibit timer, if configured, starts
- All non-disconnected indicating programmed to the input are activated provided that Aux disconnect is not active
- Non-disconnected strobes associated with the input are activated
- Non-disconnected signals associated with the input are activated at the evacuation rate

Subsequent alarms when the panel is already in alarm, cause the following:

- The alert buzzer sounds steadily
- If Signals have been silenced, they are resounded, the Signal Silence LED turns OFF, and the Auto Signal Silence timer, if configured, is restarted
- Any additional non-disconnected strobes associated with the input are activated continuously
- Any additional non-disconnected signals associated with the new input are activated at the evacuation rate



Note: All circuits with process type designated as “signal” are automatically correlated to the “fire drill” and “general alarm” status.

Input Types

The following is a table of input types available for programming.

Input Types	Description
Non-Verified Alarm	<p>When an un-bypassed non-verified alarm input goes into alarm the common alarm sequence is activated. Un-bypassed relay, signal, and strobe outputs are updated according to their programming and alarm zone status indicators associated with the input are activated. Alarm input activations are displayed on the shared display in the common queue with alarm as the highest priority and is displayed first.</p> <p>A pre-alarm condition on a device configured as an alarm input is displayed on the shared display and on the alarm zone status indicator. If the pre-alarm condition is restored the status will be cleared. If the input goes from pre-alarm to alarm, the pre-alarm status will be replaced with the alarm status for the input.</p> <p>Once an alarm input is in alarm the alarm condition is latched until system reset (changes in status from alarm to pre-alarm or to normal are ignored).</p>

Input Types	Description
Verified Alarm	<p>When an un-bypassed verified alarm input goes into alarm, if the system is not already in alarm, the alarm is verified over a period of time to determine if the alarm condition is valid. For addressable analog devices, when a device goes into alarm, a 35 second timer is started. When the 35 second delay times out, the device is monitored for the next 60 seconds, if it goes into alarm again during this time the alarm is confirmed. Once the alarm condition is confirmed, the alarm is processed as for non-verified inputs.</p> <p>If the system goes into alarm at any point during verification process (due to an alarm on another device or circuit), the verification process is aborted and the alarm is immediately confirmed. If another Verified Alarm Input goes into alarm during the verification process, the verification is aborted and the alarm is confirmed on both inputs. A trouble detected on the circuit being verified during the verification period will also cause the verification to be aborted and the alarm confirmed.</p> <p>An alarm zone status indicator flashes during the alarm verification process. If the alarm is confirmed the indicator will go steady, otherwise it will be turned off.</p> <p>Once the system is in alarm verified alarm circuits operate the same as non-verified circuits. The pre-alarm condition on verified alarm inputs is processed the same as non-verified inputs; i.e.. it is not verified.</p> <p>A count is maintained of the number of times each verified input has gone through its verification process without confirming an alarm. These counts can be retrieved for reporting purposes and cleared.</p>
Waterflow Alarm	<p>Waterflow inputs are sampled every second. If 10 samples are in alarm in any given 15 second period, an alarm condition is confirmed and the alarm is processed as for non-verified inputs.</p> <p>The alarm zone status indicator flashes whenever even one sample indicates an alarm condition. If the alarm is confirmed the indicator will go steady, it will be turned off when 15 seconds elapse without any samples in the alarm condition. The waterflow retard operation operates regardless whether or not the system is in alarm.</p> <p>Note: Do not use the retard operation with any external retarding device.</p>
Non-Latching Supervisory	<p>When an un-bypassed supervisory input goes into alarm the common supervisory sequence is activated. Un-bypassed relay, signal, and strobe outputs are updated according to their programming and supervisory zone status indicators associated with the input are activated. Supervisory activations are displayed on the shared display in the common queue with supervisory as the second highest priority.</p> <p>When a non-latched supervisory input is restored, outputs programmed to it also return to normal unless they are also programmed to other active inputs. Zone display indicators will also be updated to indicate that the input is no longer active and the message will be removed from the shared display common queue. If there are no other active supervisory inputs the common supervisory condition will be restored.</p>
Latching Supervisory	<p>Latched supervisory inputs operate the same as non-latched supervisory inputs except that the alarm condition is latched: restoration of the circuit (from alarm to normal) is ignored until system reset.</p>
Monitor	<p>Monitor input status may be reflected on monitor zone indicators and in the common queue, with monitor having the lowest priority on the shared display. They may also be programmed to relay, signal, and strobe outputs. When an un-bypassed monitor circuit goes into alarm, the status display and programmed outputs are activated. When it restores the status display, the outputs restore unless they are also programmed to other active inputs.</p>

Input Types	Description
Trouble-Only	<p>An alarm condition on an un-bypassed trouble only input initiates the common trouble sequence as a non-latching trouble. The status is reflected on trouble zone indicators and in the common queue on the shared display with trouble-only as the third priority. They may also be programmed to relay, signal, and strobe outputs.</p> <p>Note that the trouble condition initiated as a result of an alarm on a trouble-only input is separate from the circuit or device supervision trouble.</p>
Remote Switch Inputs	<p>Remote switch inputs may be used to provide remote control of system common controls. Remote switches are processed as a toggle operation. When the circuit is activated it sends an event through the system similar to pressing the switch on the front panel. When the circuit is restored it is ignored. For example if a remote switch is associated with the fire drill common control activating it once when drill is not activated will turn on drill and activating it again will turn off drill.</p> <p>Remote switches are supervised to ensure that they do not get "stuck" in the "ON" position. If they remain active for more than 30 seconds a circuit trouble is generated. The trouble is non-latching and goes away when the input is restored.</p> <p>Remote switches themselves are not correlated to relay, signal, and strobe outputs although the feature they are associated with may be.</p>

Output Types

Output Type	Description
Signal	<p>This output type is for audible devices such as bells and piezo mini-horns. Signals operate in alert (two stage) and/or evacuation rate.</p>
Strobe	<p>Normal (non-sync): Strobe circuits operate similar to signals except that they are always turned ON continuously (they are not affected by the alert or evacuation rates) if configured as normal. When configured as normal the output circuit does not use any sync protocol. Normal strobes can be silenceable or non-silenceable.</p> <p>Synchronized: Output circuits configured as strobes can have sync protocol for synchronization. When the output circuit is configured as strobe and also configured as non-silenceable and the device used on the output is a combination of horn and strobe, then if the signal silence is activated while the circuit is active the horn(s) are silenced while the strobe keeps on flashing. Synchronized strobes and strobe/horn models of the following manufacturers are supported: Faraday, System Sensor, Wheelock, Gentex (Secutron), and Summit.</p>
Relay	<p>Un-bypassed relay outputs are activated if any un-bypassed input circuit or common system status which has been programmed to it is active. If the relay is configured as "silenceable" it is inhibited when common auxiliary disconnect is active. Relays also turned off if they are bypassed or if all inputs and system status correlated to it are restored or bypassed.</p>



Note: Silencing of the horn depends on the feature provided by the manufacturer of the horn/strobe combination. Some models of the horn/strobe combination may not have this feature and will not work as described above.

Evacuation Codes

Continuous	On 100% of the time
Temporal Code	3 of 0.5 second ON, 0.5 second OFF then, 1.5 second pause
March Code	0.5 second ON, 0.5 second OFF
California Code	5 seconds ON, 10 seconds OFF

Figure 17: Evacuation Codes

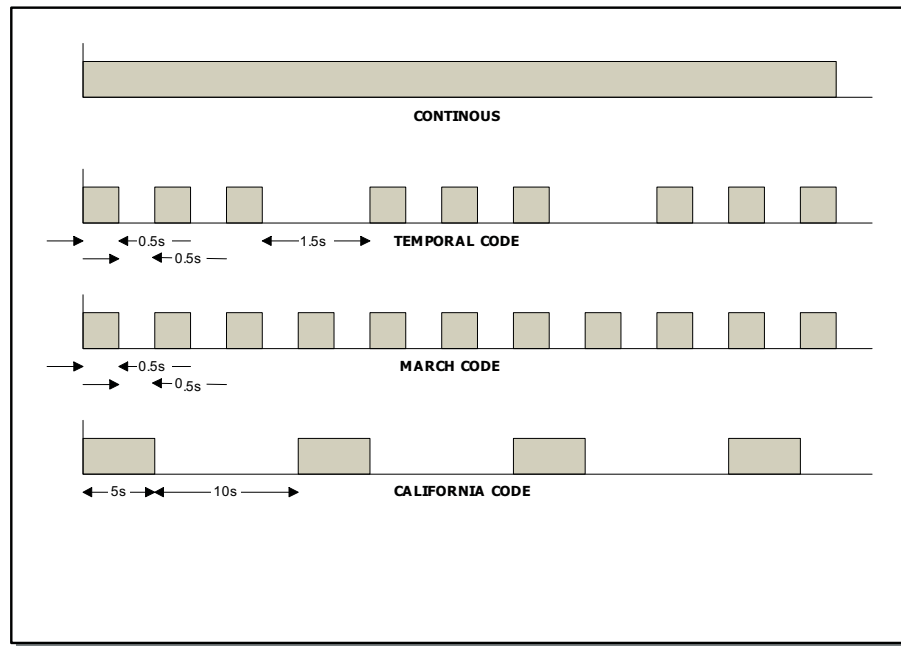

Initial Power-up Sequence

When the system powers up, it performs an initial self diagnostic and executes a system reset to reset all external devices. The common trouble sequence is then initiated. The system must be reset manually to clear the trouble. At power-up, a check is performed on the configuration data, program, and RAM memory. If an error is found, the system is placed in trouble but the system attempts to continue to operate.







The power-up sequence will occur when power is first applied to the panel, when power is restored after a total power failure (including battery power), or when the watchdog timer expires. It is also implicitly executed when the system comes out of configuration mode after auto-configure or a new configuration has been downloaded from the configurator.

The power-up complete status is set to indicate that the system power-up is complete and the system is in normal operating mode.

Shared Display

The shared display consist of a 2 line by 20 characters LCD and alpha numeric keys. It operates in three basic modes: status display mode, queue display mode and command mode. Status display mode displays system activity when the queues are empty. When there are items in the queues, queue display mode is used to browse the status of all active points in the queues. Command mode which allows the user to execute certain commands, performs certain system tests and front panel configuration of the system.

The following push buttons are used by the shared display:

	<p>UP/DOWN</p> <ul style="list-style-type: none"> - scroll through common alarm, supv, trouble and monitor queue - scroll through menu selections when in command mode
	<p>RIGHT/LEFT</p> <ul style="list-style-type: none"> - moves to next or previous field or digit in command mode - Make selection for example checking/un-checking the selection box - Right key to add items for example Remote LED groups, correlation etc. - Left key to delete items for example led groups etc.
	<p>INFO</p> <ul style="list-style-type: none"> - displays additional information for the currently selected item in queue display mode or when a pre-alarm, alarm verification or retard operation is active in status display mode
	<p>MENU</p> <ul style="list-style-type: none"> - enter command mode or returns to base menu if already in command mode
	<p>ENTER</p> <ul style="list-style-type: none"> - accepts currently selected item or menu selection in command mode
	<p>CANCEL</p> <ul style="list-style-type: none"> - cancels current operation in command mode and returns to previous menu, or exits command mode if at base menu
<p>ALPHA NUMERIC KEYS</p> 	<ul style="list-style-type: none"> - Some commands require the entry of numeric values, for example loop and device address for device configuration or changing the time etc. - Some configuration requires entering the alpha keys for example the labels for circuits. Multiple key presses are required for entering an appropriate alpha character. First key press enters the numeric character, the second key press enters the first alpha character and another key press will enter the second alpha character and so on. The sequence is repeated with subsequent key presses.

Status Display Mode

The display is in status display mode when there are no items in the queue and command mode is not active. When there are no active alarms on the system, the display will show a system normal message. By default the message is displayed in the following format

System Normal
12: 47 MON 2005 - 10- 03

When there is a pre-alarm, alarm verification active or retard verification is in process on a device the system normal message is replaced by a message in the following format:

Pre-al arm detected
12: 47 MON 2005 - 10- 03

OR

Al arm veri fi cati on
12: 47 MON 2005 - 10- 03

OR

Retard veri fi cati on
12: 47 MON 2005 - 10- 03

If the device or circuit returns to normal, the system normal message will be re-displayed. If multiple pre-alarms or alarm verification sequences are active at the same time only the first is displayed. Pressing the INFO button while the pre-alarm or verification message is active will display additional information on the circuit or device as described under queue display mode.

Queue Display Mode

Active inputs are all combined together and displayed in one queue with alarm, supervisory, trouble, or monitor and having priority in the same sequence as they are listed with alarm as the highest priority. In addition any internal non-fatal troubles which will cause the common trouble sequence to be activated will also result in a specific message to be placed in the queue with trouble level priority. The message is displayed in the following format:

Signal opt
Short ckt trb 01/04

Pressing 'INFO' Key

Conventional signal
Lp: 0 Addr: 002

Where:

- the first line shows the process type and the input or output designation
- the second line shows the active status or the trouble status depending on the circuit type and the location of the message in the queue along with the total number of messages in the queue
- pressing the INFO key give some additional information
- the first line shows the process type
- the second line shows the loop# where the device is connected and the device address

For internal troubles the 2 line message is an internally formatted message which identifies the trouble along with any additional information which can help in diagnostics. Whenever there are active inputs in any of the queues the display will automatically display the oldest un-viewed event in the highest priority queue. The queue priority is as follows: alarm (highest), supervisory, trouble, monitor (lowest). During queue display mode, the messages in the queue can be scrolled using the UP and DOWN key. For non-latching inputs (monitors, non-latching supervisory, non-latching troubles) the message is removed from the queue when the circuit is restored. Latching input types will only be removed at system reset.

Remote Annunciators Operation

The SFC-500 supports two types of annunciators: conventional LED/switch annunciators and a shared display (LCD) annunciator. Both types are connected to the panel via the RS-485 serial link.

Conventional Annunciators (SRA-300 Series and SRAM-216 and SRAM-208)

The SFC-500 is designed to interface with the SRA-300 series and SRAM-216 and SRAM-208 conventional LED annunciators. The LEDs may be configured to zone status indicators. Each conventional annunciator contains a local alert buzzer. Under normal operation the alert buzzer is controlled by the system and operates in an identical manner as the one in the main panel. If communication fails it is processed locally.

Supervision

The communications with each annunciator is constantly supervised both by the panel and by the annunciator. If communications fails, the panel will activate the common trouble sequence. The number of annunciators is set during panel configuration. If there is a mismatch in the total number of annunciators the panel will generate communications trouble. The panel trouble is non-latching: when the correct number of annunciators is detected the troubles will clear.

Shared Display Annunciator (SRAM-200LCD)

The shared display annunciator has identical operation to the main shared display and operates in conjunction with the main display (viewing items in the queues on one shared display flag the items as viewed on all shared displays). The shared display annunciator contains a local alert buzzer. Under normal operation the alert buzzer is controlled by the system and operates in an identical manner as the one in the main panel. If communication fails it is processed locally. The configuration cannot be performed by the shared display annunciator.

Supervision

The supervision of the shared display annunciator is same as for the remote LED annunciators

The SSR-212 Smart Relay Module is connected on the RS-485 loop along with other remote annunciators, but provides 12 relay contact outputs which actuate according to the first 12 remote LED groups. The relays are bypassed by Auxiliary Bypass, and the unit is supervised as one of the (maximum) seven permitted annunciators.

Dialer Operation

The SFC-500 Series (models with a D suffix) Fire Control panels are equipped with a built-in dialer. The dialer provides a means to communicate panel status to the remote central monitoring station using two dedicated phone lines.

There are many standard protocols for communicating with the central monitoring station, but the two most commonly used are supported by this panel

- SIA DCS
- Contact ID

Event Reporting

Events are reported in a special format depending upon the protocol selected.

Telephone line supervision

The phone lines are supervised for the presence of

- DC voltage
- dial tone, stuttered dial tone and message waiting tone

The supervision is carried out every two minutes; first the DC voltage is supervised and if it is detected the dial tone is monitored. If the phone lines are equipped with a house phone and with proper connection if the house phone is in use the supervision is suspended until the house phone is ON-HOOK again.

If there is an event to be reported in the dialer queue and the house phone is in use the dialer tries the second line to report the event if that line's house phone is also in use the dialer seizes the line thus disconnecting the house phone and reports the event.

Appendix A: Compatible Receivers

The dialers that are built into select models of the SFC-500 Series Fire Alarm Control Panels are compatible with the following Digital Alarm Communicator Receivers (DACR):

DACR Receiver Model

SurGard MLR2 Multi-Line Receiver (ULC, ULI approved)
 SurGard SLR Single-Line Receiver (ULC, ULI approved)
 Osborne-Hoffman Quickalert! II Receiver (ULI approved)
 Osborne-Hoffman OH-2000 Receiver (ULI Approved)
 Silent Knight Model 9500 Receiver (ULI Approved)
 Radionics Model D6500 Receiver (ULI Approved)
 Radionics Model D6600 Receiver (ULI Approved)

Protocols

SIA-DCS and Ademco Contact ID
 SIA-DCS and Ademco Contact ID
 SIA-DCS and Ademco Contact ID
 SIA-DCS and Ademco Contact ID
 SIA-DCS and Ademco Contact ID
 SIA-DCS and Ademco Contact ID
 SIA-DCS and Ademco Contact ID

Appendix B: Reporting

Ademco Contact-ID

SFC-500 Event Codes

Description	Event Family	Qualifier	Code	Group #	Contact #
Phone Line #1 trouble detected	Trouble	New event	1 351	00	000
Phone Line #2 trouble detected	Trouble	New event	1 352	00	000
Phone Line #1 trouble restored	Trouble	Restore	3 351	00	000
Phone Line #2 trouble restored	Trouble	Restore	3 352	00	000
Failure to report to an Account	Trouble	New event	1 354	Acct #	Acct #
Report to an Account successful	Trouble	Restore	3 354	Acct #	Acct #
RS-485 Communication Trouble	Trouble	New event	1 350	00	485
Periodic (24 hr) Test Event (NORMAL)	Test	New event	1 602	00	000
Periodic (24 hr) Test Event (OFF NORMAL)	Test	New event	1 608	00	000
Manually initiated dialer test	Test	New event	1 601	00	000
Zone Fire Alarm	Alarm	New event	1 110	00	NNN
Zone Fire Alarm restored	Alarm	Restore	3 110	00	NNN
Zone Trouble detected	Trouble	New event	1 300	00	NNN
Zone Trouble restored	Trouble	Restore	3 300	00	NNN
Zone Supervisory condition	Supervisory	New event	1 200	00	NNN
Zone Supervisory restored	Supervisory	Restore	3 200	00	NNN
Water flow	Alarm	New event	1 113	00	NNN
Water flow restored	Alarm	Restore	3 113	00	NNN
Indicating Zone Trouble	Trouble	New event	1 320	00	NNN
Indicating Zone Trouble restored	Trouble	Restore	3 320	00	NNN
General Alarm	Alarm	New event	1 140	00	NNN
General Alarm restored	Alarm	Restore	3 140	00	NNN
AC power lost	Trouble	New event	1 301	00	000
AC power restored	Trouble	Restore	3 301	00	000
Battery Low	Trouble	New event	1 302	00	000
Battery Low restored	Trouble	Restore	3 302	00	000
Ground Fault	Trouble	New event	1 310	00	000
Ground Fault restored	Trouble	Restore	3 310	00	000

Security Industries Association SIA-DCS

SIA protocol does not define indicating zone troubles, but lists it as Untyped Zone Trouble/Restore.

SFC-500 Event Codes

Event Description	Event Family	Qualifier	SIA Event Code	Parameter
Phone Line #1 trouble detected	Trouble	New event	LT	001
Phone Line #2 trouble detected	Trouble	New event	LT	002
Phone Line #1 trouble restored	Trouble	Restore	LR	001
Phone Line #2 trouble restored	Trouble	Restore	LR	002
Failure to report to an Account	Trouble	New event	RT	Acct #
Report to an Account successful	Trouble	Restore	YK	Acct #
RS485 Communication Trouble	Trouble	New event	YS	485
Periodic (24 hr) Test Event (Normal)	Test	New event	RP	000
Periodic (24 hr) Test Event (Off-normal)	Test	New event	RY	000
Manually initiated dialer test	Test	New event	RX	000
Zone Fire Alarm	Alarm	New event	FA	NNN
Zone Fire Alarm restored	Alarm	Restore	FH	NNN
Zone Trouble detected	Trouble	New event	FT	NNN
Zone Trouble restored	Trouble	Restore	FJ	NNN
Zone Supervisory condition	Supervisory	New event	FS	NNN
Zone Supervisory restored	Supervisory	Restore	FR	NNN
Water flow alarm	Alarm	New event	WA	NNN
Water flow alarm restored	Alarm	Restore	WH	NNN
General Alarm	Alarm	New event	QA	NNN
General Alarm restored	Alarm	Restore	QH	NNN
Indicating Zone Trouble (*)	Trouble	New event	UT	NNN
Indicating Zone Trouble restored (*)	Trouble	Restore	UR	NNN
AC power lost	Trouble	New event	AT	000
AC power restored	Trouble	Restore	AR	000
Battery Low	Trouble	New event	YT	000
Battery Low restored	Trouble	Restore	YR	000
Ground Fault	Trouble	New event	YP	000
Ground Fault restored	Trouble	Restore	YQ	000

Appendix C: Specifications

<p>SFC-500 Series Fire Control Panel</p> <p>Digital signal processor based design, fully configurable from front panel with password protection</p> <p>Electrical ratings</p> <p><i>AC line voltage</i></p> <p>120VAC 60Hz/240VAC 50Hz, 10A slow blow fuse on secondary of transformer</p> <p><i>Power supply rating</i></p> <p>5.5 Amp maximum (secondary of transformer)</p> <p>Battery</p> <p><i>Type</i></p> <p>24VDC Gel Cell/Sealed lead acid – 10AH to 24AH</p> <p><i>Charging capability</i></p> <p>10AH to 24AH</p> <p><i>Protection</i></p> <p>10A on board (F1) slow blow micro fuse</p> <p><i>Addressable loop</i></p> <p>One analog loop capable of addressing 60 or 126 Summit addressable devices.</p> <p>Power Limited</p> <p>37VDC/400mA, maximum loop resistance depends on number of devices and device type.</p> <p>Indicating Circuits</p> <p>4 supervised style Y (Class B) indicating circuits, configured as strobes or audibles. Terminals are labelled as “SIG 1”, “SIG 2”, “SIG 3” and “SIG 4”</p> <p><i>Rating</i></p> <p>Power limited / Regulated 24VDC FWR / 1.7A @ 49C per circuit</p> <p><i>Max power allowed</i></p> <ul style="list-style-type: none"> • 5A • 1.7A (aux power unfiltered if used) • 0.5A (aux power filtered if used) • 0.3A (resettable auxiliary power if used) <p>If no auxiliaries are used the max power is 5A for the indicating circuits.</p> <p>Aux supply resettable</p> <p>power limited / 21.1Vdc regulated / 500mA max</p> <p>Resettable Auxiliary Power (Aux 2)</p> <p>Power limited/21.1VDC regulated / 300mA max</p>	<p>Unfiltered supply</p> <p>Power limited / Regulated 24VDC FWR / 1.7A max at 49C</p> <p>Auxiliary relays</p> <p><i>Common Alarm/Supv./Trouble/Auxiliary Alarm</i></p> <p>Must be connected to a listed power-limited source of supply Form-C/28VDC/1A max</p> <p>RS-485 port</p> <p>For remote annunciators. Terminals are labelled “RS-485”.</p> <p>SOCA-204 Output Class A Converter Module</p> <p>Standby 0mA / alarm 0mA</p> <p>SRAM-332/332TZ Zone Remote Annunciator</p> <p>Standby 50mA / alarm 150mA (300mA for the TZ version)</p> <p>SRAM-208/216 Zone Remote Annunciator</p> <p>Standby 35mA / alarm 90mA</p> <p>SRAM-200LCD LCD Remote Annunciator</p> <p>Standby 16mA / alarm 40mA</p> <p>SRTI -200 Remote Trouble Indicator</p> <p>Standby 35mA / alarm 35mA</p> <p>SPR-200 - Polarity Reversal and City Tie Module</p> <p><i>City Tie</i></p> <p>power limited / 24VDC unfiltered / 250mA max /14Ohms trip coil</p> <p><i>Polarity Reversal</i></p> <p>power limited / 24VDC open / 12VDC at 3.5mA / 8.5mA max (shorted)</p> <p><i>Polarity Reversal Supv. Terminal</i></p> <p>24VDC (normal) / -24VDC (supervisory) / 0V (trouble)</p> <p><i>Polarity Reversal Alarm Terminal</i></p> <p>24VDC (normal) / -24VDC (alarm) / 0V (trouble)</p> <p><i>Current Consumption</i></p> <p>standby 50mA / alarm 300mA (city tie in use) / alarm 70mA (city tie not in use)</p>
---	--

Appendix D: Power Supply and Battery Calculations

POWER REQUIREMENTS (ALL CURRENTS ARE IN AMPERES)							
Model Number	Description	Qty		STANDBY	TOTAL STANDBY	ALARM	TOTAL ALARM
SFC-500-60-DR/ SFC-500-126-DR	Main Panel c/w Dialer		X	0.220	=	0.380	=
SPR-200	Polarity Reversal and City Tie Module		X	0.050	=	0.300	=
SRAM-200-LCDR	Remote LCD Annunciator		X	0.016	=	0.040	=
SRAM-332 / SRAM-332TZ	Remote Annunciator, 32 Zone LEDs		X	0.050	=	0.150 / 0.300	=
SRAM-208/216	Remote Annunciator, 8 Zone LEDs		X	0.0350	=	0.090	=
SRTI-200	Remote Trouble Indicator		X	0.035	=	0.035	=
SII-200	Ionization Detector		X	0.00028	=	0.00028	=
SIP-200	Photoelectric Detector		X	0.00034	=	0.00034	=
SIM-200	Multi-sensor		X	0.00047	=	0.00047	=
SIH-200	Heat Detector		X	0.00025	=	0.00025	=
SIM-100P	Priority Monitor Module		X	0.00023	=	0.00023	=
SIM-101P	Mini Priority Monitor Module		X	0.00060	=	0.00060	=
55000-820	Relay Output Module		X	0.00085	=	0.00085	=
SIM-100S	Supervised Control Module		X	0.00100	=	0.00100	=
SIM-100X (Kit) 100XH (Isolator) 100XB (Base)	Isolator c/w Mounting Base		X	0.000035	=	0.000035	=
SIB-6R	Relay Base		X	0.000002	=	0.000040	=
Device and Remote LEDs (Maximum 30)			X			0.0040	=
Signal Load (bells, horns, strobes, and etc.)			X				=
Auxiliary Power Supply for Annunciators, etc. (See Note 2)					=		=
Total currents (Add above currents)				STANDBY(A)		ALARM (B)	=

... continued on next page



Notes: 1. Assumes 25% of Zone LEADS (i.e. 15) are ON during alarm.
 2. See specific installation documentation for standby and alarm currents for other annunciators listed in Panel Components and Accessories. Observe maximum auxiliary power supply ratings for lamp test conditions for remote annunciators.

Battery Capacity Requirement:

Battery (AH) = (Standby Current Total x Discharge Time) + (Alarm Current Total x Alarm Time)

$$([STANDBY (A) \text{ _____}] \times [(24 \text{ or } 60 \text{ Hours}) \text{ ____}]) + ([ALARM (B) \text{ _____}] \times [Alarm \text{ in Hr. } \text{ ____}]) = (C) \text{ _____ AH}$$

Total Alarm Current must be **5.5** amperes or less. Indicating Circuits must not to exceed **5** amperes.

Battery Selection:

Battery Size = Multiply (C) by 1.20 to derate battery.

Summit recommends the following batteries for use with this panel:

BATTERY SIZE	SUMMIT
12AH	BA-110
18AH	BA-117
26AH	BA-124

Batteries: BA-110 (12 AH) will fit into the SFC-500 backbox.

BA-117 (18 AH) and BA-124 (26 AH) batteries will fit into the BC-160 Battery Cabinet.

Use of alternative batteries may result in failure of the panel to meet agency and regulatory requirements, and may result in shortened battery life. Batteries should be tested regularly, and replaced at least every three years.

Warranty & Warning Information

Warning Please Read Carefully

Note to End Users: This equipment is subject to terms and conditions of sale as follows:

Note to Installers

This warning contains vital information. As the only individual in contact with system users, it is your responsibility to bring each item in this warning to the attention of the users of this system. Failure to properly inform system end-users of the circumstances in which the system might fail may result in over-reliance upon the system. As a result, it is imperative that you properly inform each customer for whom you install the system of the possible forms of failure.

System Failures

This system has been carefully designed to be as effective as possible. There are circumstances, such as fire or other types of emergencies where it may not provide protection. Alarm systems of any type may be compromised deliberately or may fail to operate as expected for a variety of reasons. Some reasons for system failure include:

•*Inadequate Installation*

A Fire Alarm system must be installed in accordance with all the applicable codes and standards in order to provide adequate protection. An inspection and approval of the initial installation, or, after any changes to the system, must be conducted by the Local Authority Having Jurisdiction. Such inspections ensure installation has been carried out properly.

•*Power Failure*

Control units, smoke detectors and many other connected devices require an adequate power supply for proper operation. If the system or any device connected to the system operates from batteries, it is possible for the batteries to fail. Even if the batteries have not failed, they must be fully charged, in good condition and installed correctly. If a device operates only by AC power, any interruption, however brief, will render that device inoperative while it does not have power. Power interruptions of any length are often accompanied by voltage fluctuations which may damage electronic equipment such as a fire alarm system. After a power interruption has occurred, immediately conduct a complete system test to ensure that the system operates as intended.

•*Failure of Replaceable Batteries*

Systems with wireless transmitters have been designed to provide several years of battery life under normal conditions. The expected battery life is a function of the device environment, usage and type. Ambient conditions such as high humidity, high or low temperatures, or large temperature fluctuations may reduce the expected battery life. While each transmitting device has a low battery monitor which identifies when the batteries need to be replaced, this monitor may fail to operate as expected. Regular testing and maintenance will keep the system in good operating condition.

•*Compromise of Radio Frequency (Wireless) Devices*

Signals may not reach the receiver under all circumstances which could include metal objects placed on or near the radio path or deliberate jamming or other inadvertent radio signal interference.

•*System Users*

A user may not be able to operate a panic or emergency switch possibly due to permanent or temporary physical disability, inability to reach the device in time, or unfamiliarity with the correct operation. It is important that all system users be trained in the correct operation of the alarm system and that they know how to respond when the system indicates an alarm.

•*Automatic Alarm Initiating Devices*

Smoke detectors, heat detectors and other alarm initiating devices that are a part of this system may not properly detect a fire condition or signal the control panel to alert occupants of a fire condition for a number of reasons, such as: the smoke detectors or heat detector may have been improperly installed or positioned; smoke or heat may not be able to reach the alarm initiating device, such as when the fire is in a chimney, walls or roofs, or on the other side

of closed doors; and, smoke and heat detectors may not detect smoke or heat from fires on another level of the residence or building.

•*Software*

Most Summit products contain software. With respect to those products, Summit does not warranty that the operation of the software will be uninterrupted or error-free or that the software will meet any other standard of performance, or that the functions or performance of the software will meet the user's requirements. Summit shall not be liable for any delays, breakdowns, interruptions, loss, destruction, alteration or other problems in the use of a product arising out of, or caused by, the software.

Every fire is different in the amount and rate at which smoke and heat are generated. Smoke detectors cannot sense all types of fires equally well. Smoke detectors may not provide timely warning of fires caused by carelessness or safety hazards such as smoking in bed, violent explosions, escaping gas, improper storage of flammable materials, overloaded electrical circuits, children playing with matches or arson.

Even if the smoke detector or heat detector operates as intended, there may be circumstances when there is insufficient warning to allow all occupants to escape in time to avoid injury or death.

•*Alarm Notification Appliances*

Alarm Notification Appliances such as sirens, bells, horns, or strobes may not warn people or waken someone sleeping if there is an intervening wall or door. If notification appliances are located on a different level of the residence or premise, then it is less likely that the occupants will be alerted or awakened. Audible notification appliances may be interfered with by other noise sources such as stereos, radios, televisions, air conditioners or other appliances, or passing traffic. Audible notification appliances, however loud, may not be heard by a hearing-impaired person.

•*Telephone Lines*

If telephone lines are used to transmit alarms, they may be out of service or busy for certain periods of time. Also the telephone lines may be compromised by such things as criminal tampering, local construction, storms or earthquakes.

•*Insufficient Time*

There may be circumstances when the system will operate as intended, yet the occupants will not be protected from the emergency due to their inability to respond to the warnings in a timely manner. If the system is monitored, the response may not occur in time enough to protect the occupants or their belongings.

•*Component Failure*

Although every effort has been made to make this system as reliable as possible, the system may fail to function as intended due to the failure of a component.

•*Inadequate Testing*

Most problems that would prevent an alarm system from operating as intended can be discovered by regular testing and maintenance. The complete system should be tested as required by national standards and the Local Authority Having Jurisdiction and immediately after a fire, storm, earthquake, accident, or any kind of construction activity inside or outside the premises. The testing should include all sensing devices, keypads, consoles, alarm indicating devices and any other operational devices that are part of the system.

•*Security and Insurance*

Regardless of its capabilities, an alarm system is not a substitute for property or life insurance. An alarm system also is not a substitute for property owners, renters, or other occupants to act prudently to prevent or minimize the harmful effects of an emergency situation.

IMPORTANT NOTE: End-users of the system must take care to ensure that the system, batteries, telephone lines, etc. are tested and examined on a regular basis to ensure the minimization of system failure.

Limited Warranty

Summit Systems Technologies warrants the original purchaser that for a period of two years from the date of manufacture, the product shall be free of defects in materials and workmanship under normal use. During the warranty period, Summit Systems Technologies shall, at its option, repair or replace any defective product upon return of the product to its factory, at no charge for labor and materials. Any replacement and/or repaired parts are warranted for the remainder of the original warranty or ninety (90) days, whichever is longer. The original owner must promptly notify Summit Systems Technologies in writing that there is defect in material or workmanship, such written notice to be received in all events prior to expiration of the warranty period.

International Warranty

The warranty for international customers is the same as for any customer within Canada and the United States, with the exception that Summit Systems Technologies shall not be responsible for any customs fees, taxes, or VAT that may be due.

Conditions to Void Warranty

This warranty applies only to defects in parts and workmanship relating to normal use. It does not cover:

- damage incurred in shipping or handling;
- damage caused by disaster such as fire, flood, wind, earthquake or lightning;
- damage due to causes beyond the control of Summit Systems Technologies such as excessive voltage, mechanical shock or
- water damage;
- damage caused by unauthorized attachment, alterations, modifications or foreign objects;
- damage caused by peripherals (unless such peripherals were supplied by Summit Systems Technologies);
- defects caused by failure to provide a suitable installation environment for the products;
- damage caused by use of the products for purposes other than those for which it was designed;
- damage from improper maintenance;
- damage arising out of any other abuse, mishandling or improper application of the products.

Warranty Procedure

To obtain service under this warranty, please return the item(s) in question to the point of purchase. All authorized distributors and dealers have a warranty program. Anyone returning goods to Summit Systems Technologies must first obtain an authorization number. Summit Systems Technologies will not accept any shipment whatsoever for which prior authorization has not been obtained. NOTE: Unless specific pre-authorization in writing is obtained from Summit management, no credits will be issued for custom fabricated products or parts or for complete fire alarm system. Summit will at its sole option, repair or replace parts under warranty. Advance replacements for such items must be purchased.

Note: Summit Systems Technologies' liability for failure to repair the product under this warranty after a reasonable number of attempts will be limited to a replacement of the product, as the exclusive remedy for breach of warranty.

Disclaimer of Warranties

This warranty contains the entire warranty and shall be in lieu of any and all other warranties, whether expressed or implied (including all implied warranties of merchantability or fitness for a particular purpose) And of all other obligations or liabilities on the part of Summit Systems Technologies neither assumes nor authorizes any other person purporting to act on its behalf to modify or to change this warranty, nor to assume for it any other warranty or liability concerning this product.

This disclaimer of warranties and limited warranty are governed by the laws of the province of Ontario, Canada.

Out of Warranty Repairs

Summit Systems Technologies will at its option repair or replace out-of-warranty products which are returned to its factory according to the following conditions. Anyone returning goods to Summit Systems Technologies must first obtain an authorization number. Summit Systems Technologies will not accept any shipment whatsoever for which prior authorization has not been obtained.

Products which Summit Systems Technologies determines to be repairable will be repaired and returned. A set fee which Summit Systems Technologies has predetermined and which may be revised from time to time, will be charged for each unit repaired.

Products which Summit Systems Technologies determines not to be repairable will be replaced by the nearest equivalent product available at that time. The current market price of the replacement product will be charged for each replacement unit.

WARNING: Summit Systems Technologies recommends that the entire system be completely tested on a regular basis. However, despite frequent testing, and due to, but not limited to, criminal tampering or electrical disruption, it is possible for this product to fail to perform as expected.

NOTE: Under no circumstances shall Summit Systems Technologies be liable for any special, incidental, or consequential damages based upon breach of warranty, breach of contract, negligence, strict liability, or any other legal theory. Such damages include, but are not limited to, loss of profits, loss of the product or any associated equipment, cost of capital, cost of substitute or replacement equipment, facilities or services, down time, purchaser's time, the claims of third parties, including customers, and injury to property.

SUMMIT MAKES NO WARRANTY OF MERCHANTABILITY OR FITNESS FOR A PARTICULAR PURPOSE WITH RESPECT TO ITS GOODS DELIVERED, NOR IS THERE ANY OTHER WARRANTY, EXPRESSED OR IMPLIED, EXCEPT FOR THE WARRANTY CONTAINED HEREIN.

